

# ISPSoft Revision History

**Version: 2.02**

Date of Publication: Feb. 01, 2013

1. An extension module wizard is added.

Users can only use this function in the projects for DVP series PLCs. After users click  on the toolbar in a program editing window, they can enable the extension module wizard.

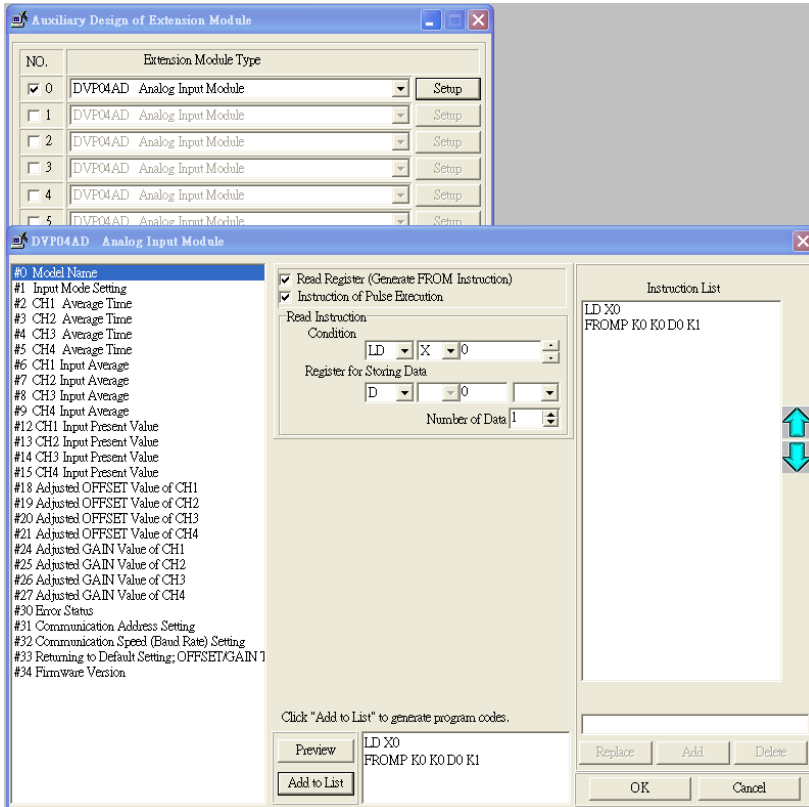

2. Users can open the **API List** window when they edit a ladder diagram.

When users type an instruction in a project for a DVP series PLC, they can click the button in the red frame shown below to open the **API List** window.

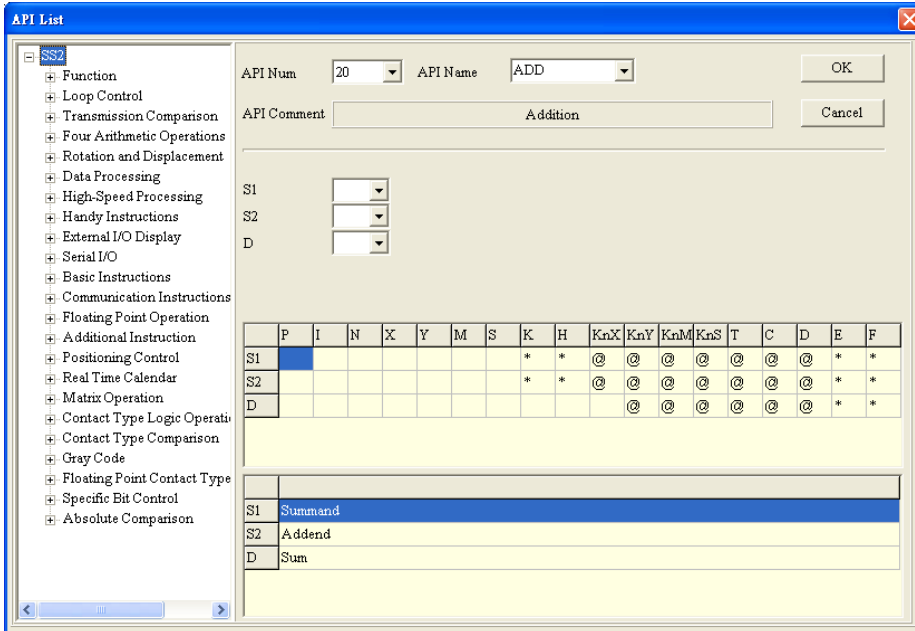
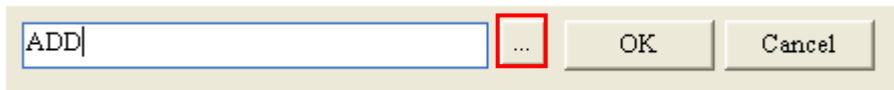

3. **Move Up (Alt+Up)** and **Move Down (Alt+Down)** are added to the context menu which will appear after users right-click a symbol table.

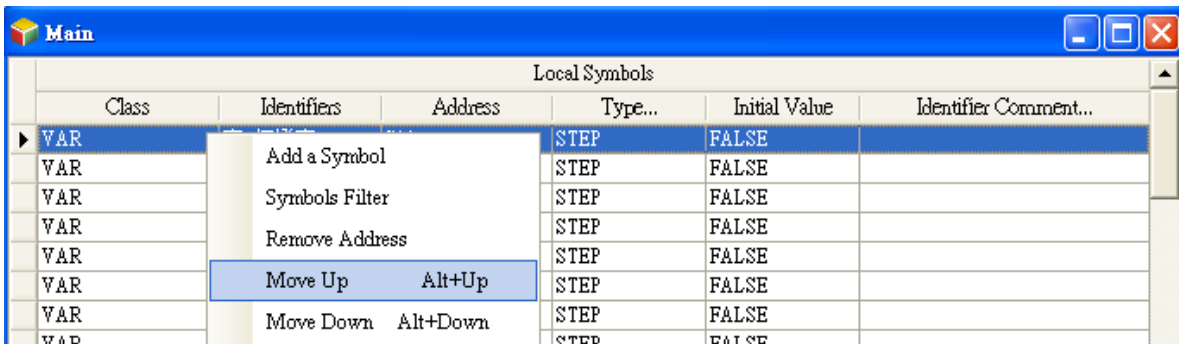

4. If the number of input/output variables of a function block used in a ladder diagram is changed, the number of pins of the function block will also be changed. If the positions of the input/output variables of a function block used in a ladder diagram are changed, the positions of the pins of the function blocks will also be changed.

5. In the projects for DVP series PLCs, the use of P labels to indicate P devices is replaced by the use of texts.

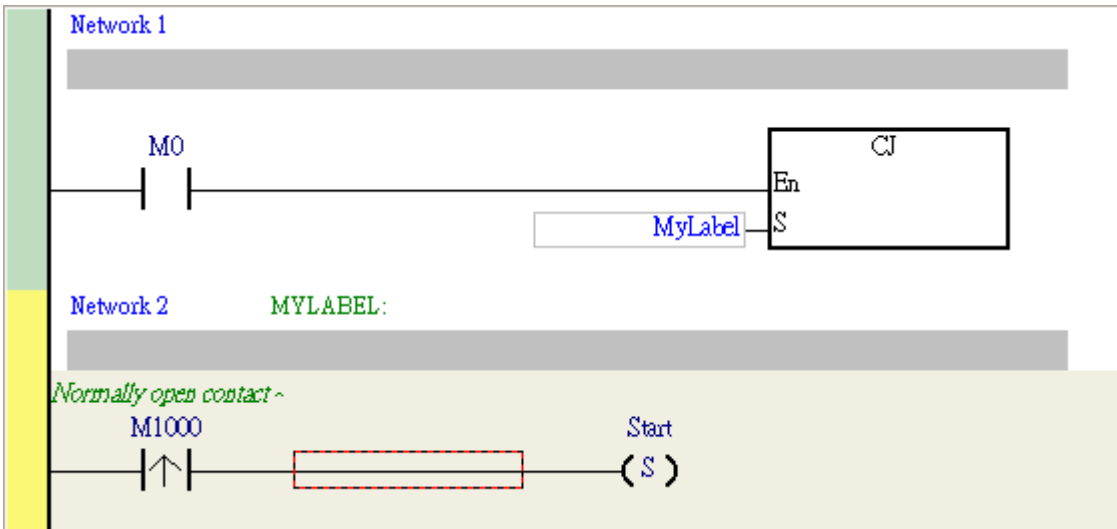

6. P (Rising), F (Falling), S (Set), and R (Reset) are added to the instructions which can be typed in a ladder diagram.

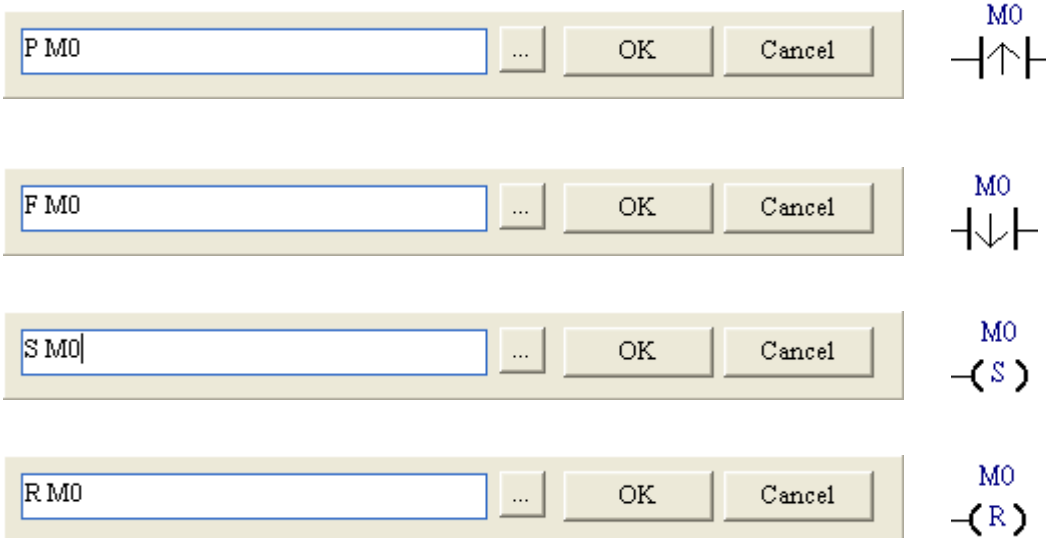

7. Owing to the fact that the firmware version of AH500 series CPU modules is updated to version 1.01, the compiler of ISPSOft is optimized. When a project is downloaded to an AH500 series CPU module, ISPSOft determines whether to compile the project again by checking the version of the AH500 series CPU module and the version of the project.
8. The online monitoring function is improved.
9. In VFD-C2000/VFD-CP2000/VFD-C200, the maximum M device address becomes M1399, and the maximum D device address becomes D1619.

10. AH10DNET-5A can be set by means of **Intelligent Module Configuration**.

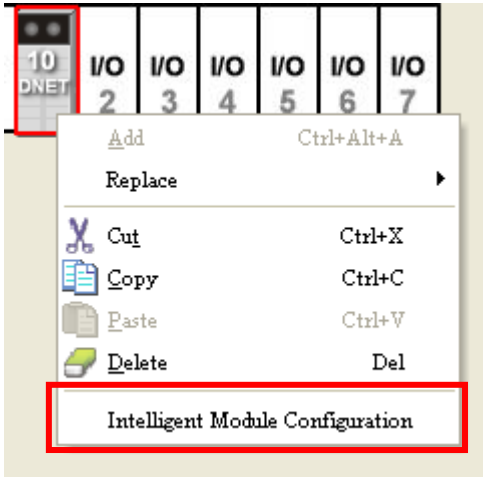

11. The assignment of devices to AH10DNET-5A is modified.

Before: The default start input/output address is 5000/6000. The default length is 0.

Parameters of IO mapping

Description	Address	Monitor	Setup	Comments
Start D device address mapped by INPUT area		<input type="checkbox"/>	5000	Start D device address
Length of D device mapped by INPUT area		<input type="checkbox"/>	0	Length of D device ma
Start D device address mapped by OUTPUT area		<input type="checkbox"/>	6000	Start D device address
Length of D device mapped by OUTPUT area		<input type="checkbox"/>	0	Length of D device ma

After: The start input address and the start output address are assigned by HWCONFI. The length specified by HWCONFIG is 500.

Parameter Setting

Parameters of IO mapping

Description	Address	Monitor	Setup	Comments
Start D device address mapped by INPUT area		<input type="checkbox"/>	0	Start D device address
Length of D device mapped by INPUT area		<input type="checkbox"/>	500	Length of D device r
Start D device address mapped by OUTPUT area		<input type="checkbox"/>	500	Start D device address
Length of D device mapped by OUTPUT area		<input type="checkbox"/>	500	Length of D device r

12. The backup file (.DUP) contains the PLC Link constructed in NWCONFIG.

## Version: 2.03

Date of Publication: June 05, 2013

- 1 The English version of the help file about the PLC Instructions and the special registers in AH series models is added.
- 2 The efficiency in monitoring a DVP series model online through Ethernet is increased. The models supported are EH3/EH3-L/SV2 version 1.80 (and above), and SA2/SX2 version 2.66 (and above).
- 3 1000 steps in a program can be edited online. The models supporting this function are SA2/SX2 version 2.66 (and above), EH3/EH3-L/SV2 version 1.82 (and above), and ES2/EX2/ES2-C version 3.22 (and above).
- 4 The ladder diagram compiler is optimized so that the number of steps in a program will be decreased after the program is compiled.
- 5 If a label is modified by an index register in the program in a DVP series PLC, e.g. Label@E0, an error occurs when the program is compiled. This prevents the execution of a program from jumping to an uncertain P address.
- 6 SA2/SX2 version 2.66 and above support the instruction FTC.
- 7 A network port is added to SE in NWCONFIG.
- 8 EH2-L and EH3-L can be connected to EN01 in NWCONFIG.
- 9 The function of setting Ethernet data exchange is added to HWCONFIG.

The function of exchanging data through Ethernet is added to AH series models. An AH series model can exchange data with a DVP series PLC or a device supporting standard Modbus instructions. Users have to set data exchange by means of HWCONFIG. An AH series CPU module whose firmware version is 1.02.0 or above must be used.

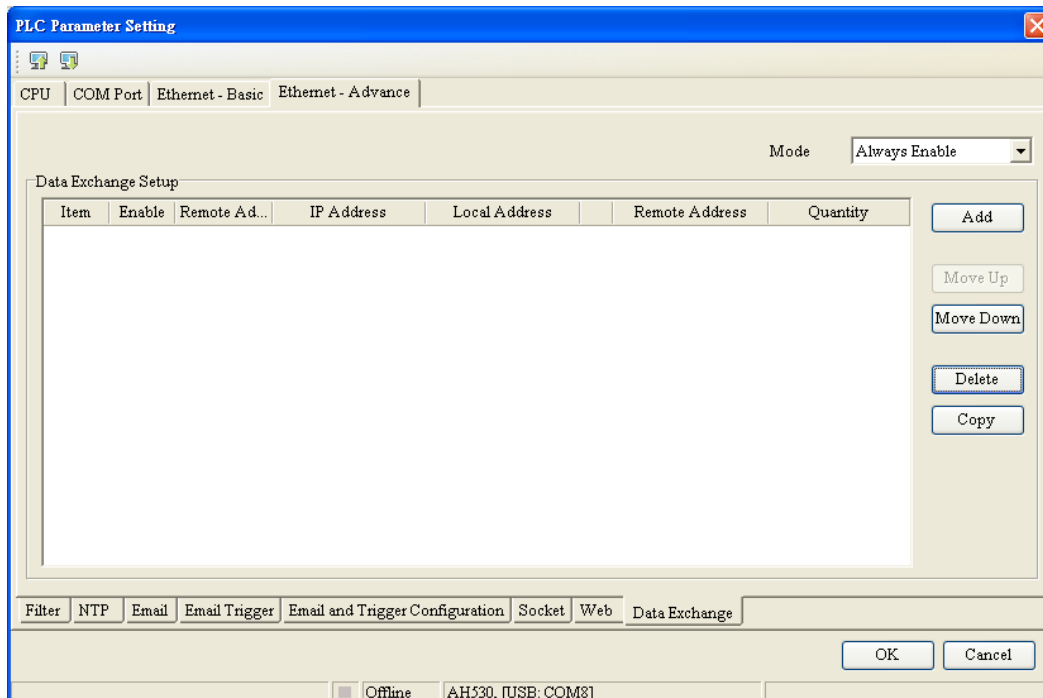

- 10 Ethernet data exchange can be backed up onto a .DUP file.

- 11 Users can change several data types in a device monitoring table at the same time. They have to select the data types which they want to change, right-click the mouse, point to **Monitor Radix** on the context menu, and click a data type.

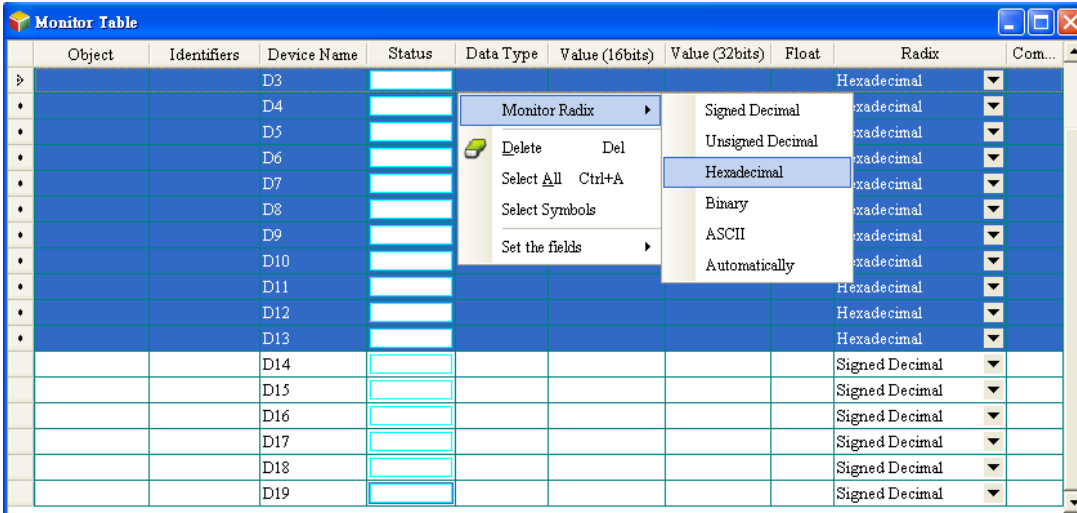

## Version: 2.04

Date of Publication: Aug. 29, 2013

- 1 The instructions MC and MCR are added to VFD series models.
- 2 The ST (structured text) compiler is modified. (The compiling of a REPEAT loop is modified.)
- 3 The problem that an error occurs when the Modbus Data Exchange parameter in HWCONFIG is downloaded to AHCPU500-EN/AHCPU510-EN/AHCPU520-EN is solved.
- 4 The inconsistency between the items on the **PO List** in HWCONFIG and the fact is resolved.
- 5 **AIO Wizard Setting** is modified. (If no module is configured, an error will occur after users click **Next**.)
- 6 **Auxiliary Setup for Extension Modules** is modified. (The instructions added to the list for an extension module may be lost if the extension module is set repeatedly.)

## Version: 2.05

Date of Publication: Sep. 19, 2014

### 1. A Delta library is added to ISPSoft.

- Usage: After users drag a Delta function block contained inside the **Delta Library** section in the project management area to the editing area, the function block will be automatically added to the project.

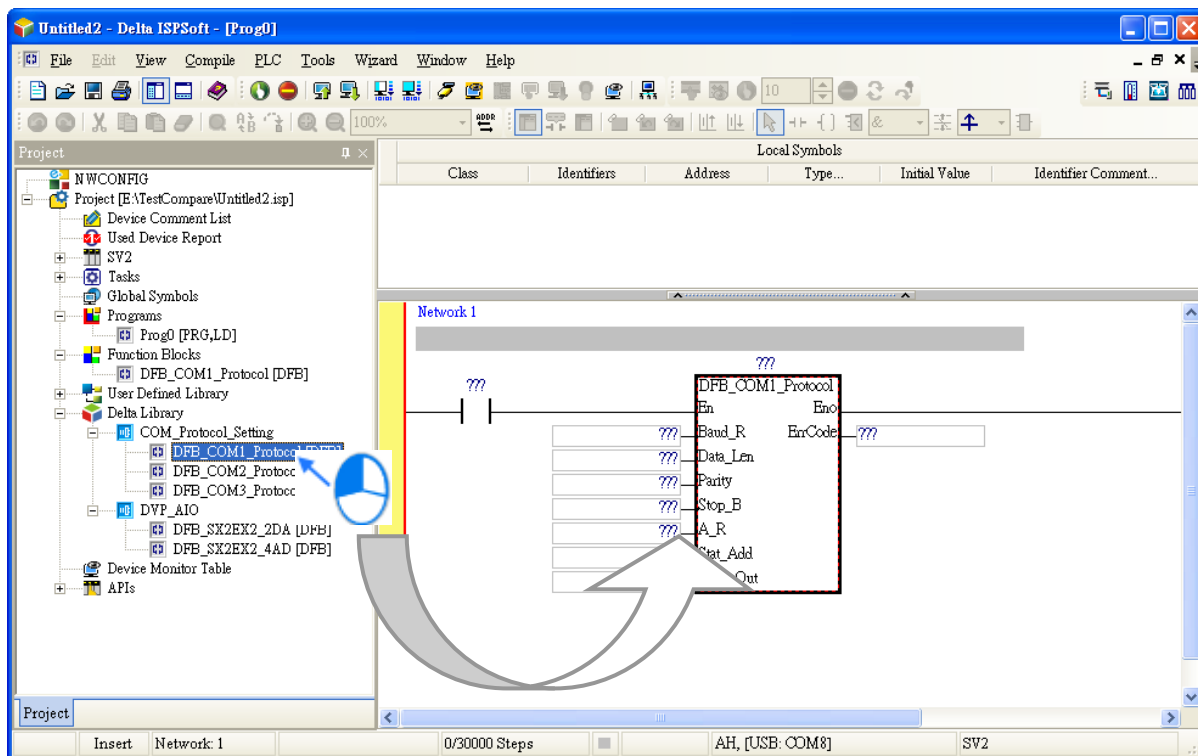

### ➤ Introduction of the Delta function blocks

- DFB\_DP\_Diag (Only for AH500 series PLCs)

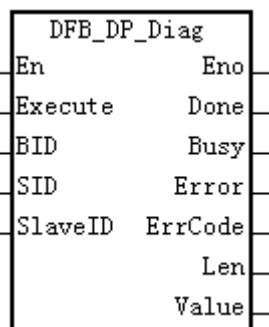

Description: When AH10PFBM-5A serves as the master, the function block can be used to achieve a diagnostic function. There are internal devices (similar to registers) for storing error messages and user-defined information in a PROFIBUS slave. An error code will be written to the devices if an error occurs in the slave. Users can read error messages and self-defined information in the PROFIBUS slave by means of the function block DFB\_DP\_Diag.

- DFB\_DPW1\_C1\_R (Only for AH500 series PLCs)

DFB_DPW1_C1_R	
En	Eno
Execute	Done
BID	Busy
SID	Error
SlaveID	ErrCode
Slot	Len
Index	Value
Size	

Description: The function block shown below is used to read data in AH10PFBM-5A.

- DFB\_DPW1\_C1\_W (Only for AH500 series PLCs)

DFB_DPW1_C1_W	
En	Eno
Execute	Done
BID	Busy
SID	Error
SlaveID	ErrCode
Slot	
Index	
Size	
Value	

Description: The function block shown below is used to write data to AH10PFBM-5A.

- DFB\_DNET\_EXP (Only for AH500 series PLCs)

DFB_DNET_EXP	
En	Eno
Excute	Done
BID	Error
SID	ErrCode
MacId	Len
SerCode	Value
ClassId	
InstId	
AttrId	
Size	
Data	

Description: When AH10DNET-5A serves as a DeviceNet master, the function block can be used to achieve the sending and the receiving of explicit messages. The function block can be used to write parameters to a slave, or read parameters in a slave.

- DFB\_FIFO\_DW (Only for AH500 series PLCs)



Description: The function block is used to read data (a double word) in the data table whose start address is specified according to FIFO. It can be used with the function block DFB\_Table\_DW. (Note: When the function block is executed, interrupts are stopped temporarily.)

- DFB\_FIFO\_W (Only for AH500 series PLCs)

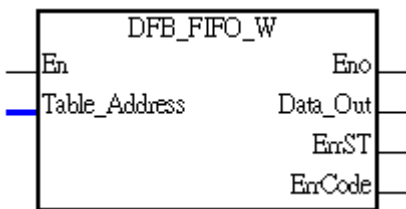

Description: The function block is used to read data (a word) in the data table whose start address is specified according to FIFO. It can be used with the function block DFB\_Table\_W. (Note: When the function block is executed, interrupts are stopped temporarily.)

- DFB\_Table\_DW (Only for AH500 series PLCs)



Description: The function block is used to put a value (a double word) in the data table whose start address is specified. It can be used with the function block DFB\_FIFO\_DW or DFB\_LIFO\_DW. (Note: When the function block is executed, interrupts are stopped temporarily.)

- DFB\_Table\_W (Only for AH500 series PLCs)

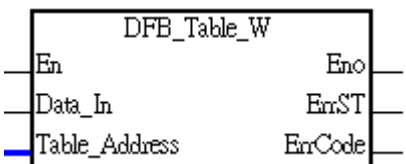

Description: The function block is used to put a value (a word) in the data table whose start address is specified. It can be used with the function block DFB\_FIFO\_W or DFB\_LIFO\_W. (Note: When the function block is executed, interrupts are stopped temporarily.)

- DFB\_LIFO\_DW (Only for AH500 series PLCs)

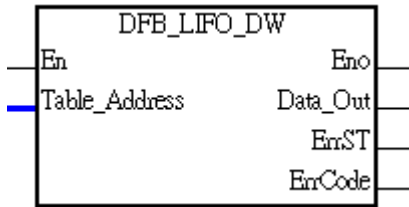

Description: The function block is used to read data (a double word) in the data table whose start address is specified according to LIFO. It can be used with the function block DFB\_Table\_DW. (Note: When the function block is executed, interrupts are stopped temporarily.)

- DFB\_LIFO\_W (Only for AH500 series PLCs)

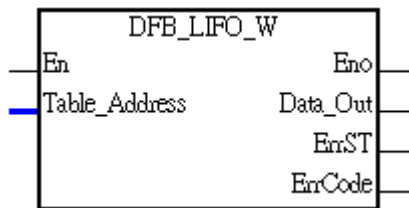

Description: The function block is used to read data (a word) in the data table whose start address is specified according to LIFO. It can be used with the function block DFB\_Table\_W. (Note: When the function block is executed, interrupts are stopped temporarily.)

- DFB\_Lead\_Lag (Only for AH500 series PLCs)

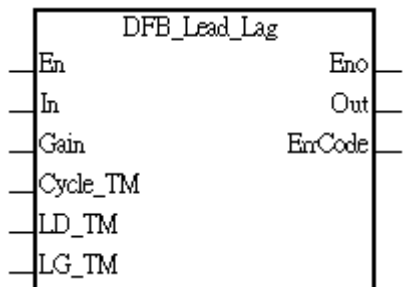

Description: When the function block is executed, the value of In is read. After a lead/lag calculation is done, the result will be sent to Out. If  $Gain \leq 0.0$  or  $Cycle\_TM + LG\_TM = 0.0$ , an error will occur. If an error occurs, the function block will not process any data, and the value of Out will remain unchanged.

- DFB\_Signal\_AVG (Only for AH500 series PLCs)

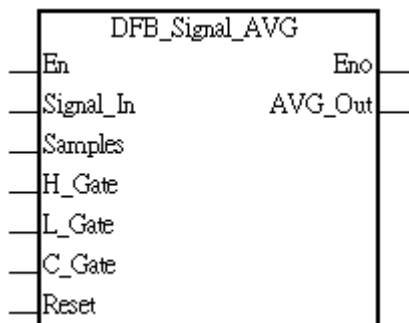

Description: When the function block is executed, Signal\_In is read. After the values read are averaged, the average will be sent to AVG\_Out. If the number of values read is greater than the setting value of Samples, the values read will be processed according to FIFO, and an average will be calculated and sent. (Note: When the function block is executed, interrupts are stopped temporarily.)

- DFB\_COM1\_Protocol, DFB\_COM2\_Protocol, DFB\_COM3\_Protocol (Only for DVP series PLCs)

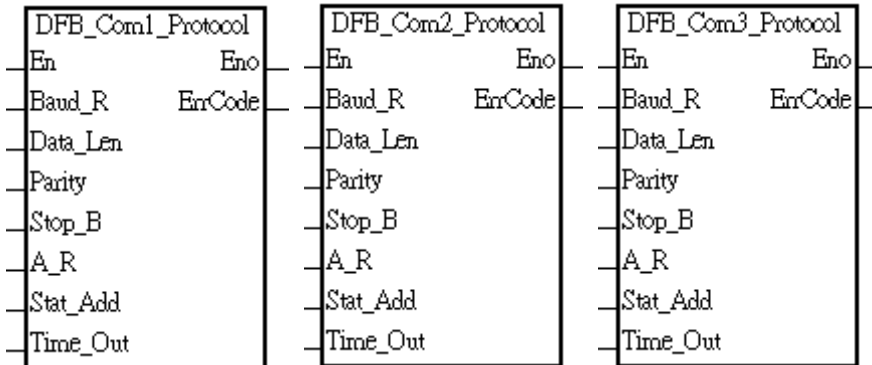

Description: Users can rapidly set the communication format of COM1/COM2/COM3, the station address of COM1/COM2/COM3, and a communication timeout without having to refer to a manual for more information about the calculation of a communication format.

- DFB\_SX2EX2\_2DA (Only for DVP series PLCs)

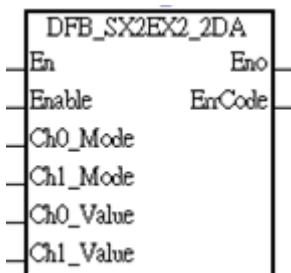

Description: Users can rapidly set the modes in which two channels in a DVP-SX2/DVP-EX2 series PLC operate and analog output without having to refer to a manual for more information about the calculation of the parameters needed.

- DFB\_SX2EX2\_4AD (Only for DVP series PLCs)

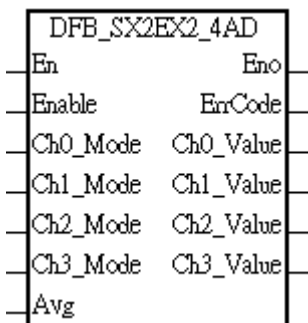

Description: Users can rapidly set the modes in which four channels in a DVP-SX2/DVP-EX2 series PLC operate and the conversion of analog input without having to refer to a manual for more information about the calculation of the parameters needed.

- If users press F1 on the keyboard after they click a function block in a ladder diagram or in the project management, they will have a more detailed description of the function block.

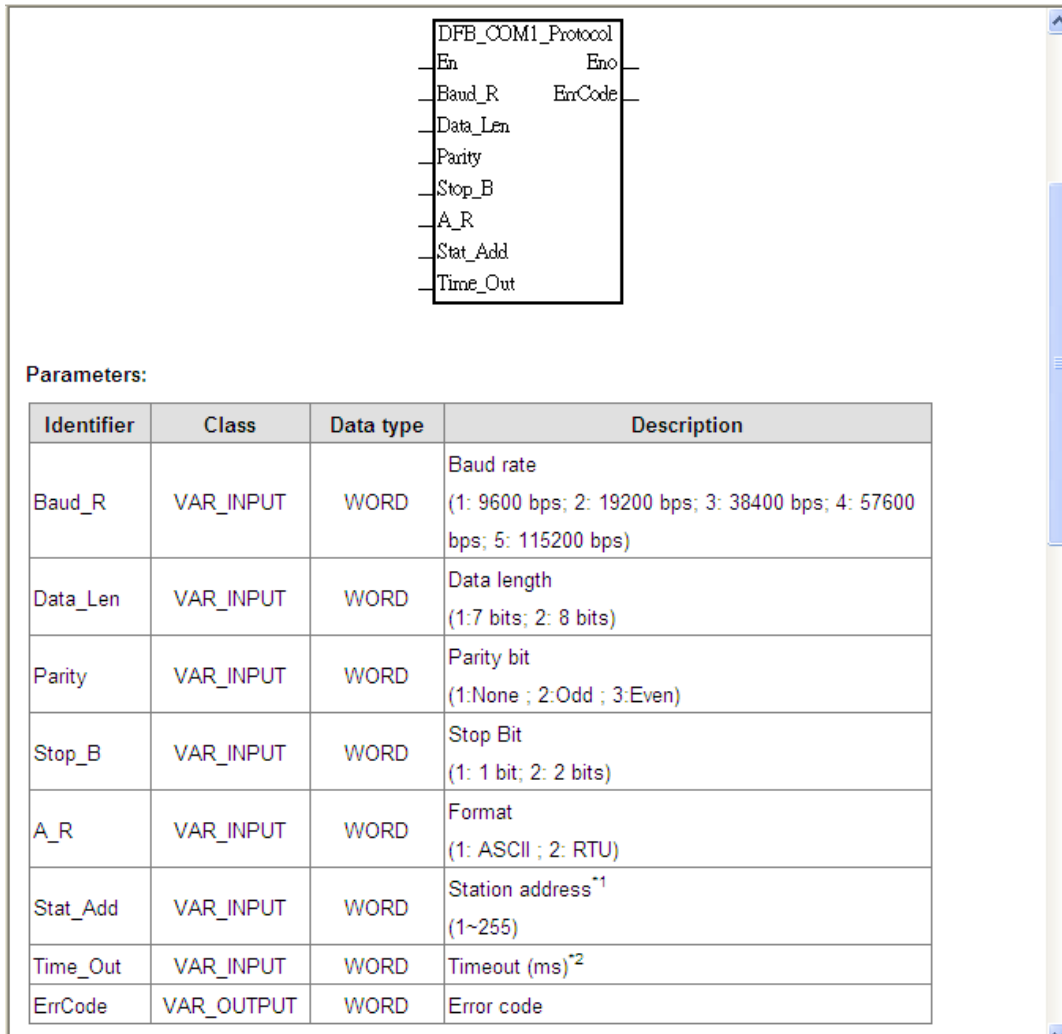

The screenshot shows a software window with a function block diagram at the top and a 'Parameters' table below it. The function block is labeled 'DFB\_COM1\_Protocol' and has several input and output terminals: En, Eno, Baud\_R, ErrCode, Data\_Len, Parity, Stop\_B, A\_R, Stat\_Add, and Time\_Out.

**Parameters:**

Identifier	Class	Data type	Description
Baud_R	VAR_INPUT	WORD	Baud rate (1: 9600 bps; 2: 19200 bps; 3: 38400 bps; 4: 57600 bps; 5: 115200 bps)
Data_Len	VAR_INPUT	WORD	Data length (1:7 bits; 2: 8 bits)
Parity	VAR_INPUT	WORD	Parity bit (1:None ; 2:Odd ; 3:Even)
Stop_B	VAR_INPUT	WORD	Stop Bit (1: 1 bit; 2: 2 bits)
A_R	VAR_INPUT	WORD	Format (1: ASCII ; 2: RTU)
Stat_Add	VAR_INPUT	WORD	Station address <sup>*1</sup> (1~255)
Time_Out	VAR_INPUT	WORD	Timeout (ms) <sup>*2</sup>
ErrCode	VAR_OUTPUT	WORD	Error code

2. A program comparison function is added to ISPSOft. It can be used to compare the current project with an .isp file on the computer.

- Usage: Open a file, point to **Program Comparison** on the **File** menu, click **Compare with File** on the context menu, and select a file.

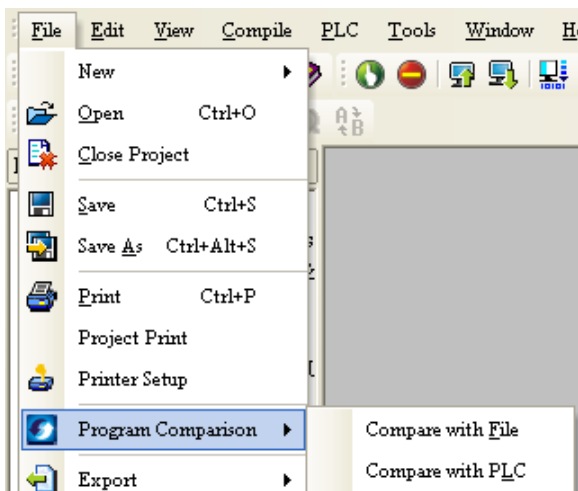

- After the current project is compared with an .isp file on the computer, the differences between the current project and the .isp file will be listed in the **Program Comparison** window. If users double-click an item in the **Program Comparison** window, the program section corresponding to the item will be displayed.

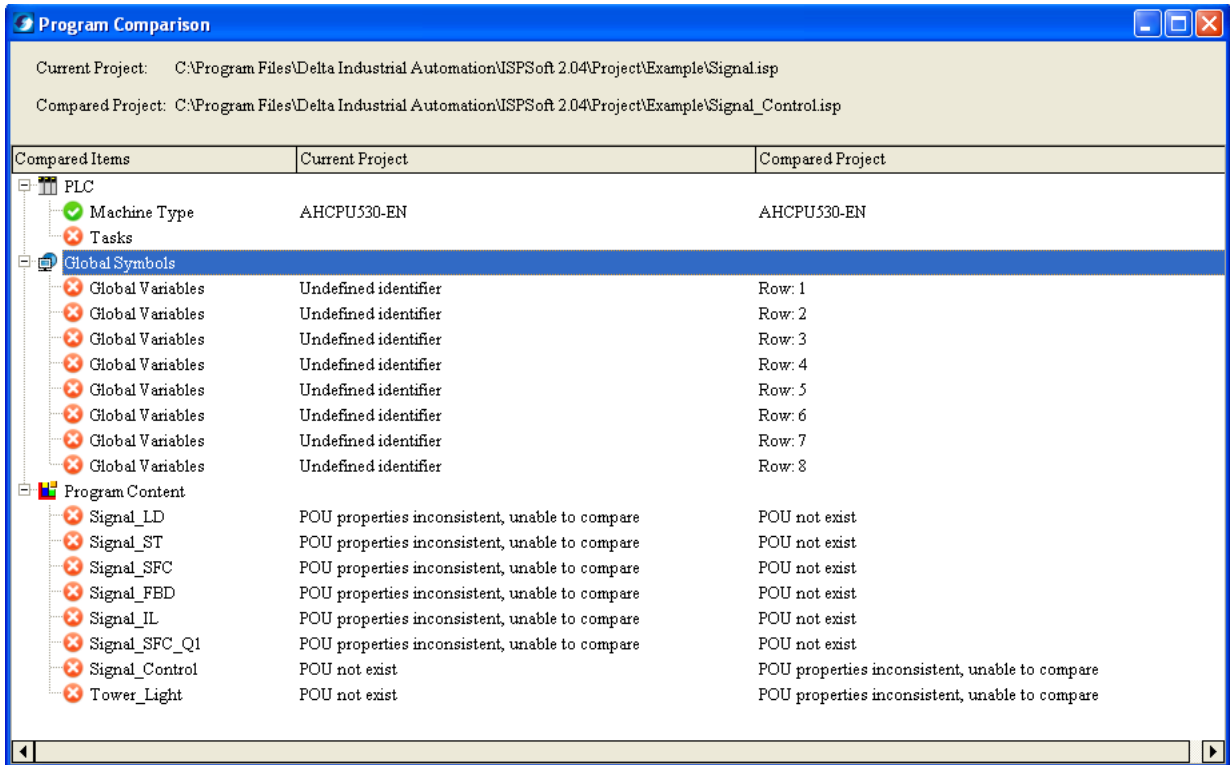

- The instruction COMRS is added to AH500 series PLCs. Please refer to **PLC Instruction and Special Registers Reference** for more information.
- The instructions DRAMP, DSORT, DRAND, MVM, DMVM, WSUM, and DWSUM are added to DVP-SX series PLCs. Please refer to **PLC Instruction and Special Registers Reference** for more information.
- The function of editing registers in an AH500 series PLC, and the function of editing the states of devices in an AH500 series PLC are added to ISPSOft.

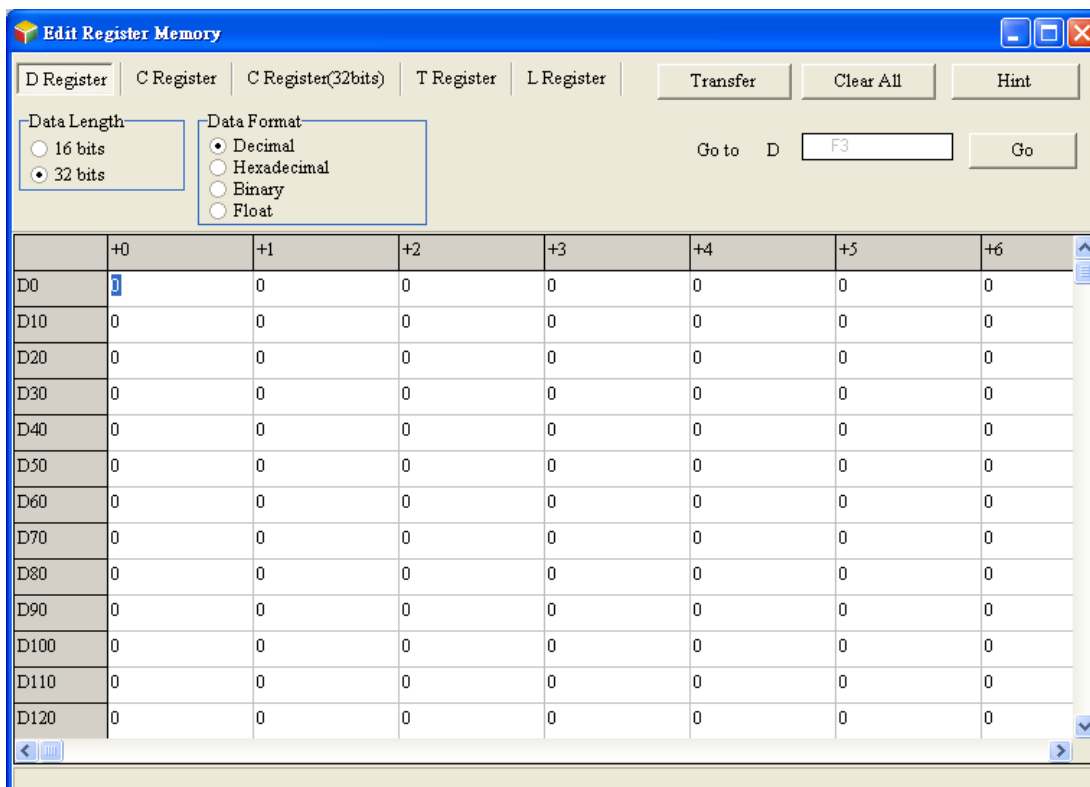

Edit Bit Memory											
M	Set the Device Online					Read the Device Online					
Go to M										F3	Go
	+0	+1	+2	+3	+4	+5	+6	+7	+8	+9	
M0	OFF	OFF	OFF	OFF	OFF	OFF	OFF	OFF	OFF	OFF	
M10	OFF	OFF	OFF	OFF	OFF	OFF	OFF	OFF	OFF	OFF	
M20	OFF	OFF	OFF	OFF	OFF	OFF	OFF	OFF	OFF	OFF	
M30	OFF	OFF	OFF	OFF	OFF	OFF	OFF	OFF	OFF	OFF	
M40	OFF	OFF	OFF	OFF	OFF	OFF	OFF	OFF	OFF	OFF	
M50	OFF	OFF	OFF	OFF	OFF	OFF	OFF	OFF	OFF	OFF	
M60	OFF	OFF	OFF	OFF	OFF	OFF	OFF	OFF	OFF	OFF	
M70	OFF	OFF	OFF	OFF	OFF	OFF	OFF	OFF	OFF	OFF	
M80	OFF	OFF	OFF	OFF	OFF	OFF	OFF	OFF	OFF	OFF	
M90	OFF	OFF	OFF	OFF	OFF	OFF	OFF	OFF	OFF	OFF	
M100	OFF	OFF	OFF	OFF	OFF	OFF	OFF	OFF	OFF	OFF	
M110	OFF	OFF	OFF	OFF	OFF	OFF	OFF	OFF	OFF	OFF	
M120	OFF	OFF	OFF	OFF	OFF	OFF	OFF	OFF	OFF	OFF	
M130	OFF	OFF	OFF	OFF	OFF	OFF	OFF	OFF	OFF	OFF	
M140	OFF	OFF	OFF	OFF	OFF	OFF	OFF	OFF	OFF	OFF	

6. The models CT2000 and CH2000, and the instructions SCLP, CATCH, BSET, MEAN, MEANP, DMEAN, and DMEANP are added to ISPSOft.
7. The editor used to edit sequential function charts is optimized.
  - The editor can be used to select several objects, copy objects, cut objects, and paste objects.

Users can click where they want to begin selection, hold down the left mouse button, and drag the pointer over the objects that they want to select. In the figure below, the area which is selected is shown in grayscale. The area can be copied or cut.

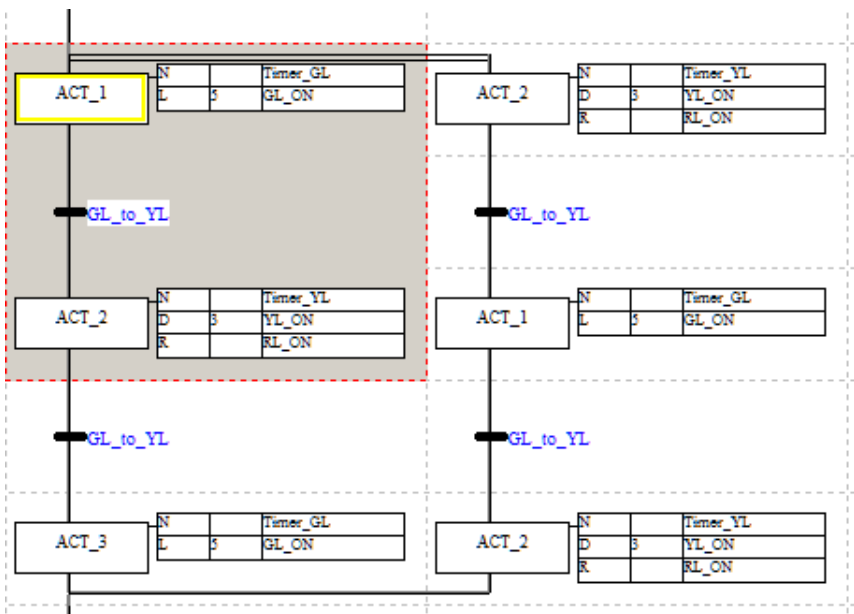

After the area is copied or cut, it can be pasted. Please see the figure below.

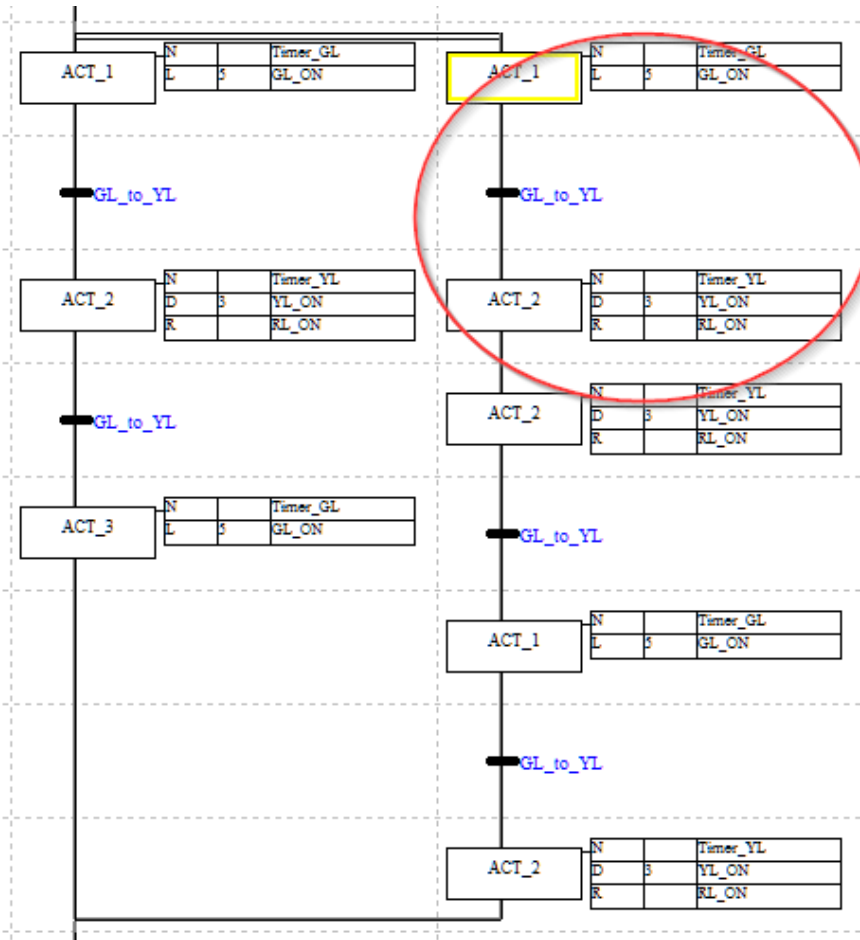

8. After users double-click an action or a transition in a window, an editing window will appear, and the two windows will be tiled horizontally but take on a vertical shape.

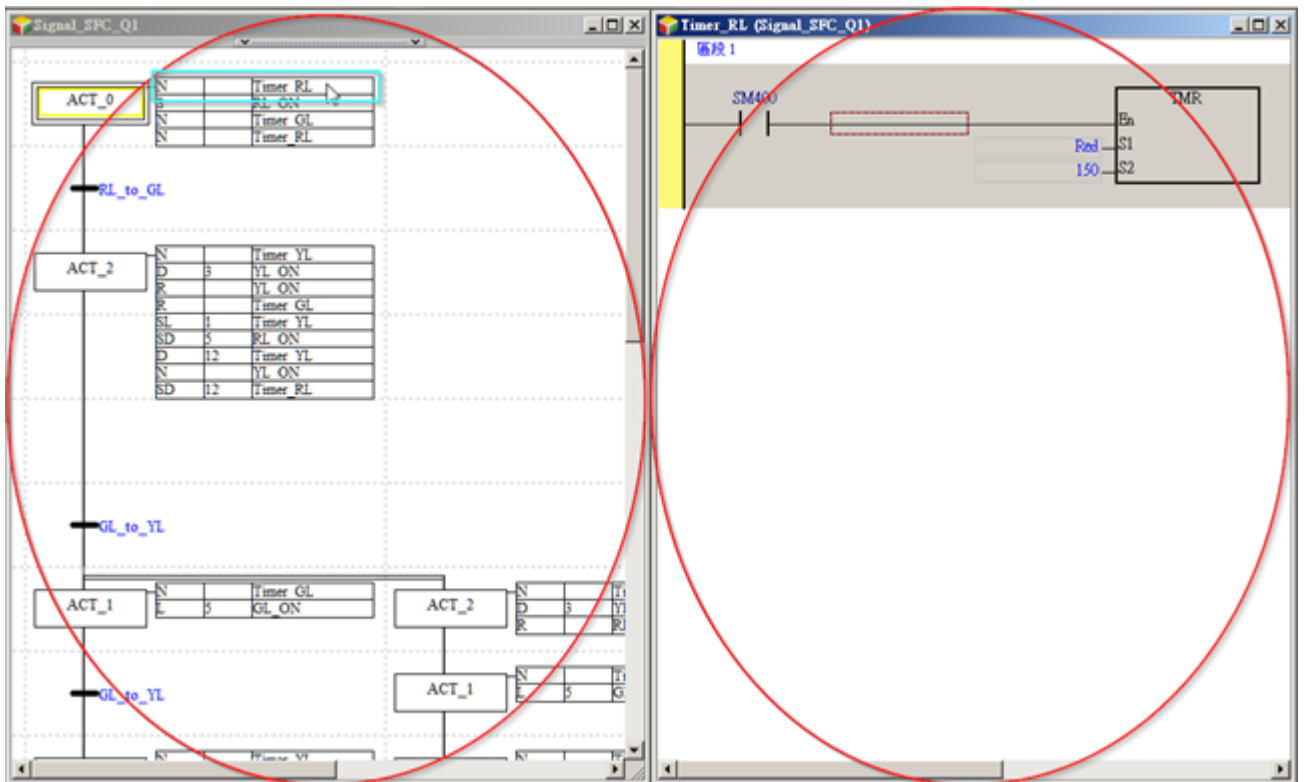

- Users can drag an action in the project management area to a step.

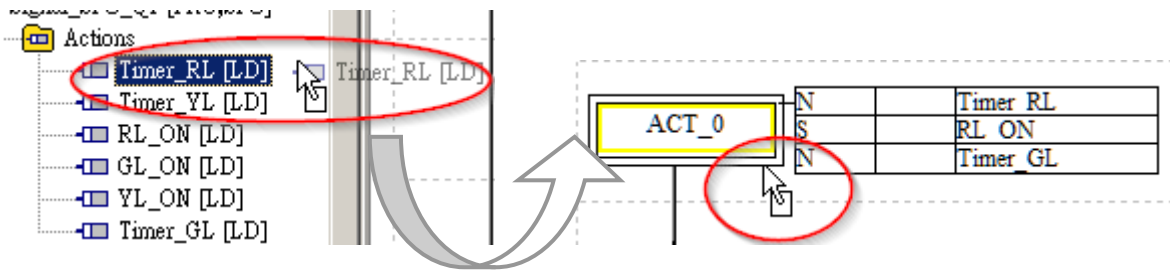

9. Global symbols are differentiated from local symbols by color. The default color of global symbols is purple. Users can set the color of global symbols in the **Options** window.

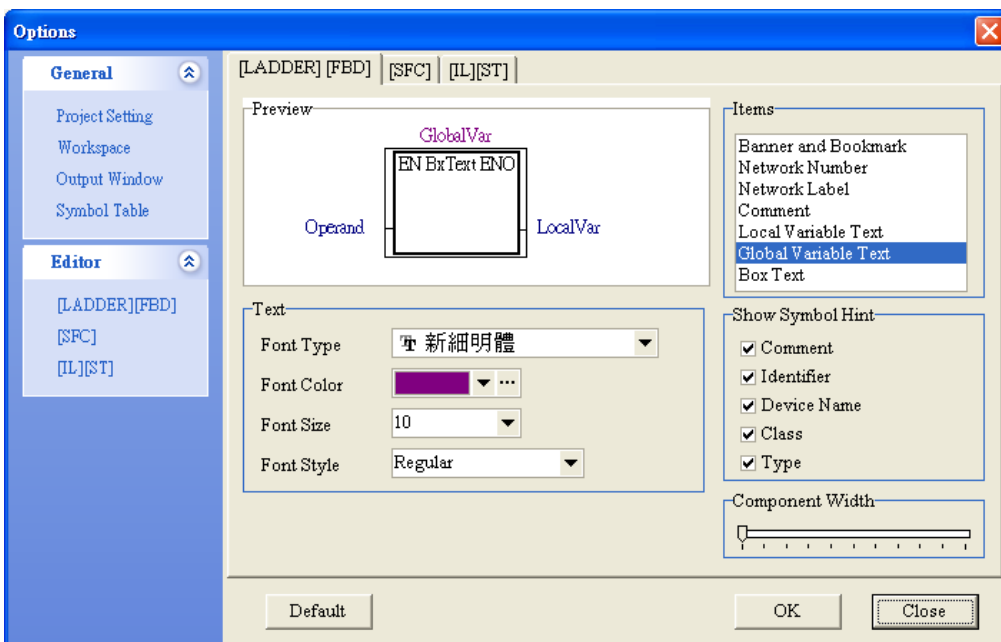
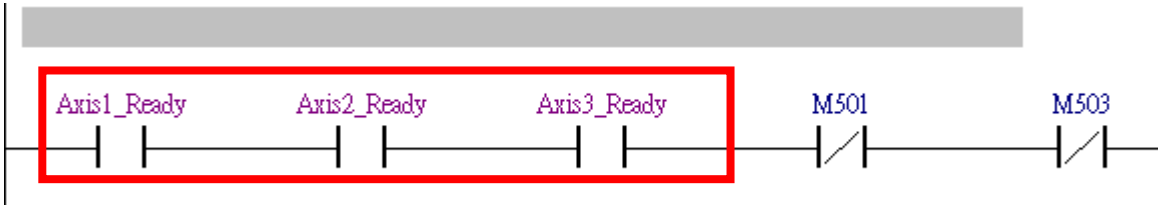

10. The **Show auto complete list** checkbox is added to the **Options** window.

If the **Show auto complete list** checkbox is selected, the variables created will appear in the drop-down list boxes in the editing windows. If there are many variables, it may take time for the variables to appear in the drop-down list boxes, and users can consider unselecting the **Show auto complete list** checkbox.

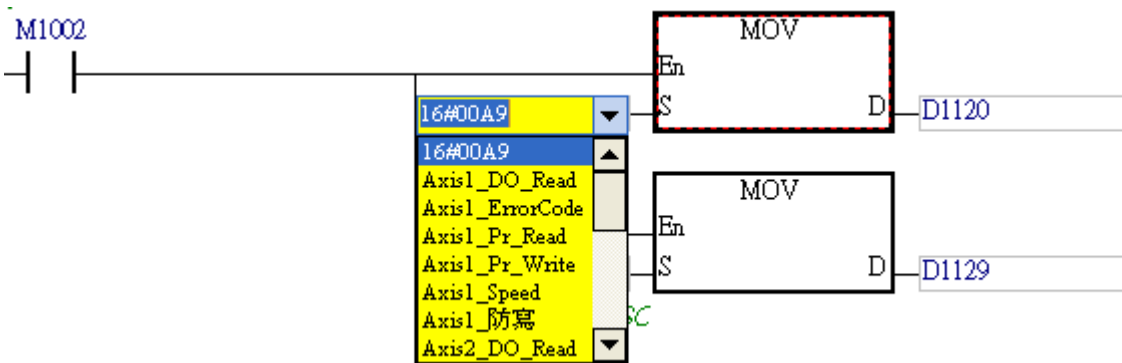

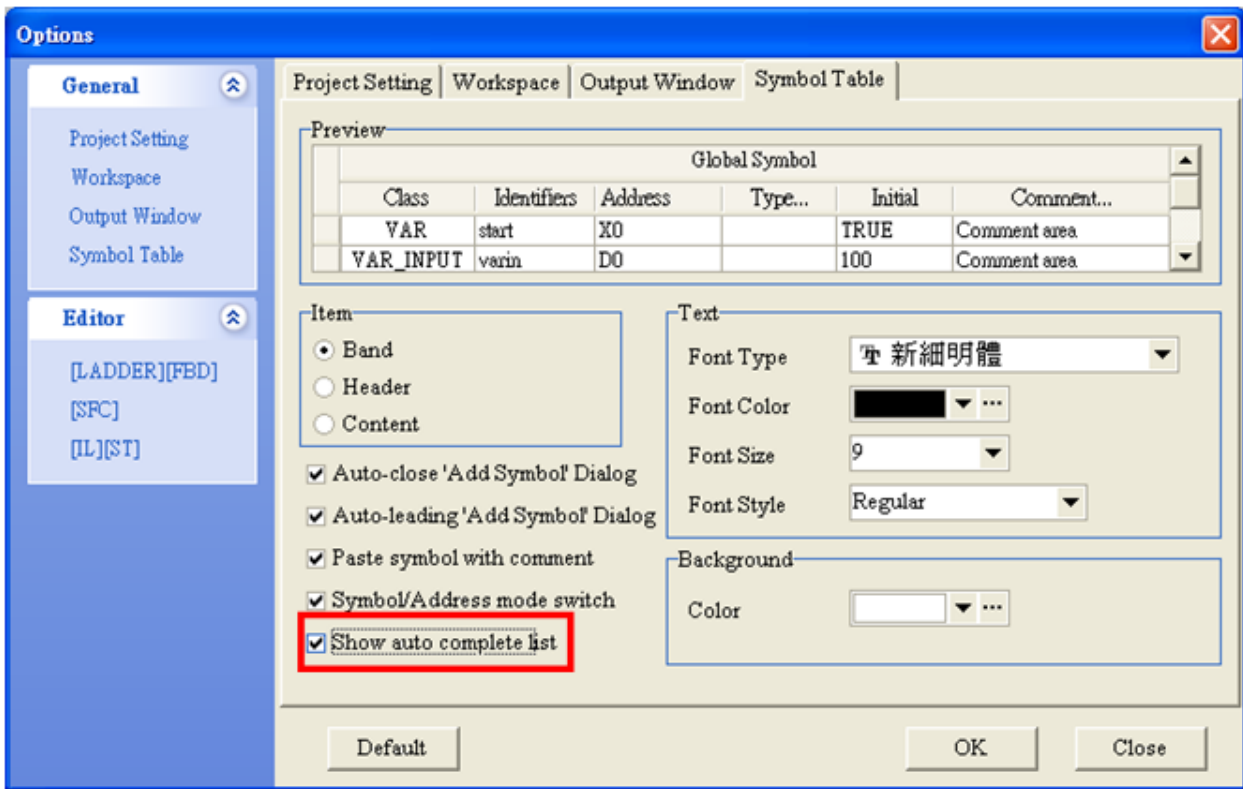

11. AH10COPM-5A is added to ISPSOft.

AH10COPM-5A is a CANopen communication module. It can function as a master station or a slave station. It provides a solution to the data exchange between an AH500 PLC and a CANopen slave station.

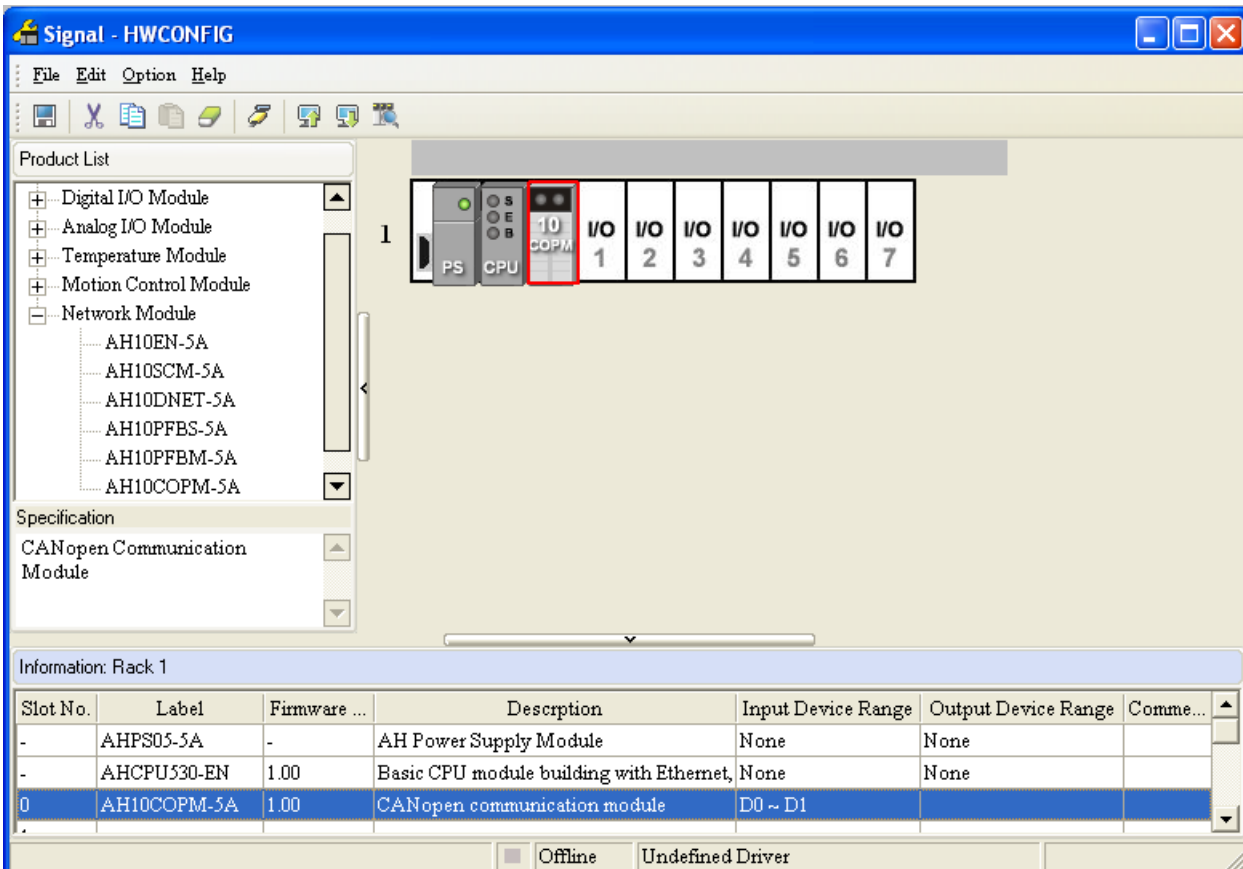

12. A memory card function is added to DVP40ES200RM. In the project created for a DVP-ES2 series PLC, users can use **PLC Memory <=> Memory Card** on the **PLC** menu.

13. Owing to the fact that DVP-ES/EC2/EC3 series PLCs are upgraded, the password function is modified so that it is similar to the password function of DVP-ES2 series PLCs.  
New password mechanism: After users set a new password, the new version of the software will automatically check whether the firmware version of the PLC used is 8.20 or above. If the firmware version of the PLC used is 8.20 or above, the PLC will be locked by the new password. If the firmware version of the PLC used is not 8.20 or above, the PLC will be locked by the old password.  
Note: After users use the new version of the software to set a new password successfully, they can not use an old version of the software to remove the password.
14. Owing to the fact that the firmware of VFD-C series models (C2000/CH2000/CT2000/CH2000-H/CP2000/C200) is upgraded, the MEAN instructions (MEAN, MEANP, DMEAN, and DMEANP) are added to the models.

## Version: 2.06

Date of Publication: Jan. 06, 2016

1. ISPSOft now can work with the following 6 new models, AHCPU511-EN, AHCPU511-RS2, AHCPU521-EN, AHCPU531-EN, TP70P-IO and TP70P-RM.
2. New function blocks are added for HVAC for DVP and AH Series. Please refer to the Help file on ISPSOft for detailed descriptions on the newly added function blocks.
  - DFB\_AirDewPoint (ver. 1.00)
  - DFB\_AirEnthalpy (ver. 1.00)
  - DFB\_AirHumRatio (ver. 1.00)
  - DFB\_AirPsychrometrics (ver. 1.00)
  - DFB\_AirVolume (ver. 1.00)
  - DFB\_AirWetBulb (ver. 1.00)
  - DFB\_CompPower (ver. 1.00)
  - DFB\_RefrigerantP2T (ver. 1.00)
3. AH Module:  
AH08DA-5A module is newly added.
4. Newly added instructions:  
New instructions are added for DVP ES2, including INITC, ASDON, CASD, DDRVIC, DDRVAC, PLSVC, ZRNC, CANWR, CANRD and COPRW. Please refer to the option "PLC instruction and Special Registers Reference" in the Help section on ISPSOft.
5. The specifications of the editor and compiler are modified.
  - All series: The first character of the variables name cannot be numeric or the compiler will send errors.
  - All series: The use of label is not allowed on the section of the instruction MCR or the compiler will send errors.
  - DVP series: The basic instructions are added to support the qualifying operands, e.g., LDP M0@E0.
  - AH series: The instruction RST is added to support the qualifying operands, e.g., RST M1000@E0.
  - AH series: Up to 32 pieces of the variables of the identifiers are available in the function block.
  - AH series: The instructions TMR, TMRH, CNT and DCNT are added to support the qualifying operands.

- AHCPU511: Instead of using the S device in the variables of the STEP type, the SFC compiler will use the internal memory in the device.

6. The editor of SFC is optimized.

New actions can be created more quickly by clicking on the ... button in the step as the image shown below.

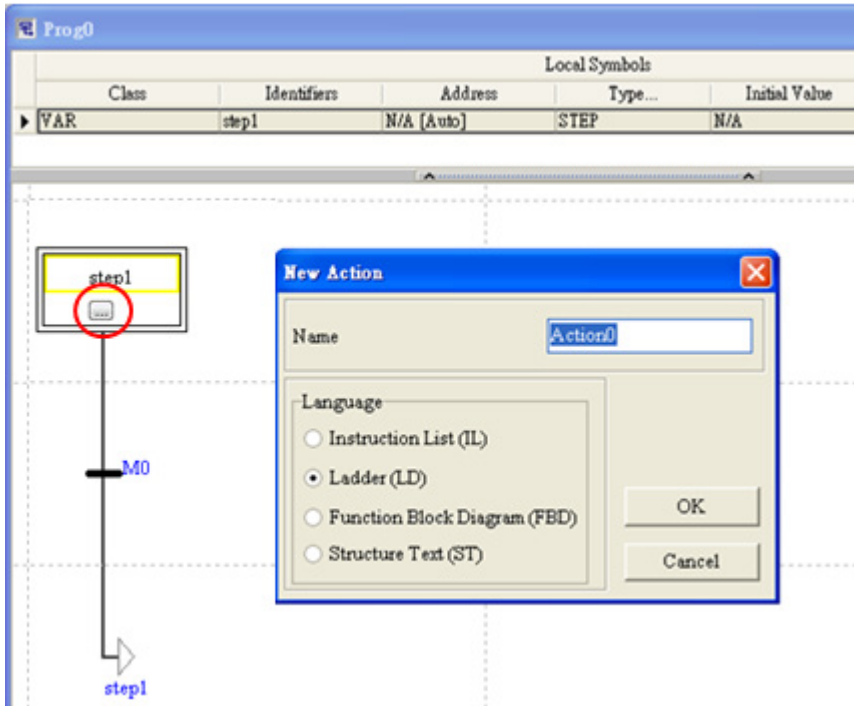

7. For ES/EC2/EC3 series with firmware V8.20 and above, password now can be edited and changed to increase the protection.  
Attention: After a new password is set via ISPSOft with new firmware V2.06, the password cannot be changed by ISPSOft with old firmware V2.05 or any previous versions.
8. For DVP series, users can add and reset the RTC functionality from the calendar window on ISPSOft.

## Version: 3.00

Date of Publication: April 18, 2016

1. ISPSOft V3.00 now supports 3 more models, including AS332T, AS332P and ASS324MT.
2. HWCONFIG for newly added models in AS series
  - Designed with no backplane, the CPU module in AS series are equipped with function card slots and can support right-side extensions. Module setups can be done in HWCONFIG; as for the extension module setups, users need to go to the PLC parameter setting window. The setups will be updated in HWCONFIG and the information list simultaneously.

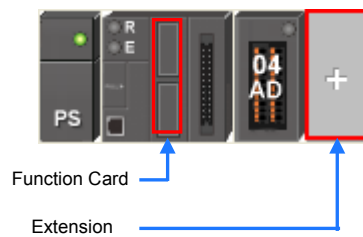

### 3. Position Planning Table

- ISPSOft V3.00 provides an easy table for users to set up the single-axis or 2-axis motion control. It is not required for users to know the complicated motion control rules to complete the setup. Create and download a position planning table and then along with the instructions, the PLC can output axis motions in the set number and order accordingly.

Click Wizard (!) > Position Planning Table on the tool bar to open the Position Planning Table window as the image shown below.

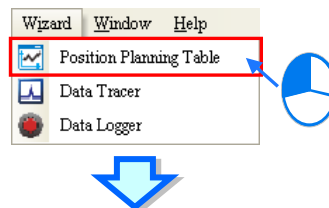

Position Planning Table

Unit Settings  
Upload Password Settings  
Positioning Settings

Displacement on axis for one motor rotation(lead)

	Enable	Value Setting	Unit Name
Axis 1	<input type="checkbox"/>	1	mm
Axis 2	<input type="checkbox"/>	1	mm
Axis 3	<input type="checkbox"/>	1	mm
Axis 4	<input type="checkbox"/>	1	mm
Axis 5	<input type="checkbox"/>	1	mm
Axis 6	<input type="checkbox"/>	1	mm

Pulses for one motor rotation(resolution)

Value Setting
1
1
1
1
1
1

Decimal Number 1

Remarks:  
1. Set the value to 1, and the output pulse number is 1, it means that the unit does not start conversion.  
2. Set the value of the actual output pulse number, only 32-bit integer input straight, but the

Default settings

Various Setups

Setup area

#### 4. Data Tracer

- Data Tracer can be used after a trigger to collect the variable symbols or values/states of a device to create a diagram of curve for users to analyze.

Before using this functionality, users need to complete the programming for the current project. Click Wizard (!) > Data Tracer on the tool bar to open the Data Tracer setup window as the image shown below.

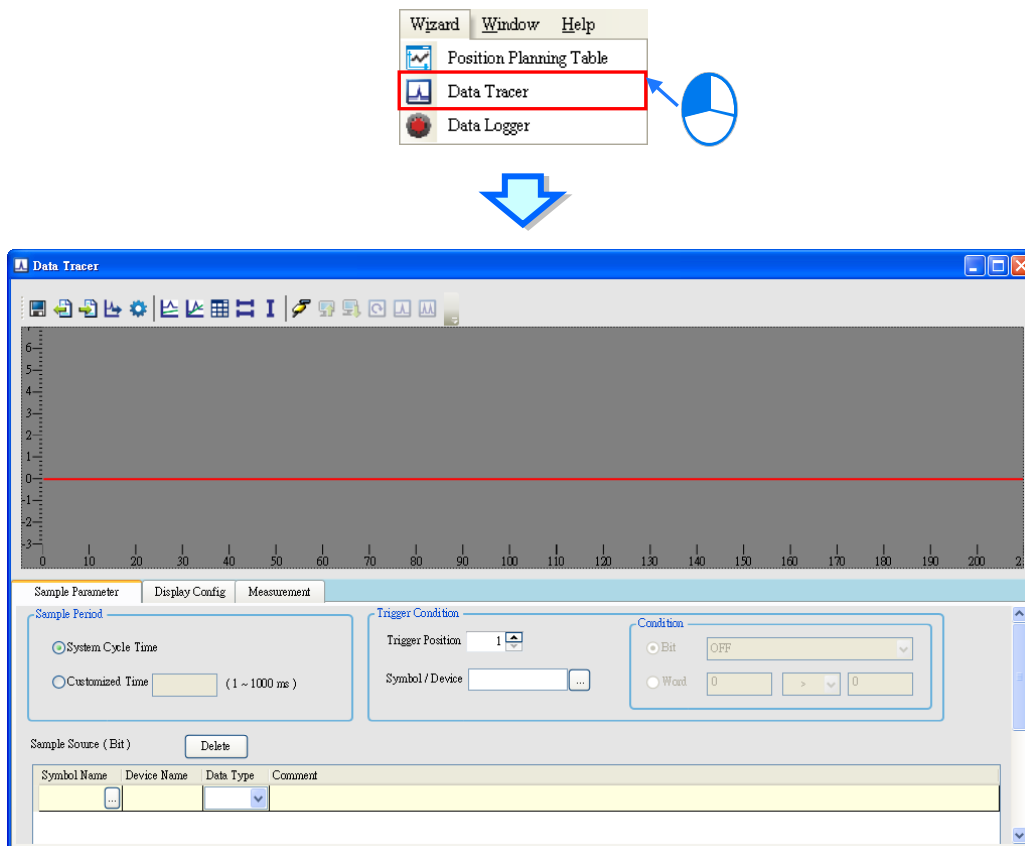

#### 5. Data Logger

- Data Logger can be used to collect the long-term records of the variable symbols or values/states of a device to create a diagram of curve for users to analyze.

Before using this functionality, users need to complete the programming for the current project. Click Wizard (!) > Data Logger on the tool bar to open the Data Logger setup window as the image shown below.

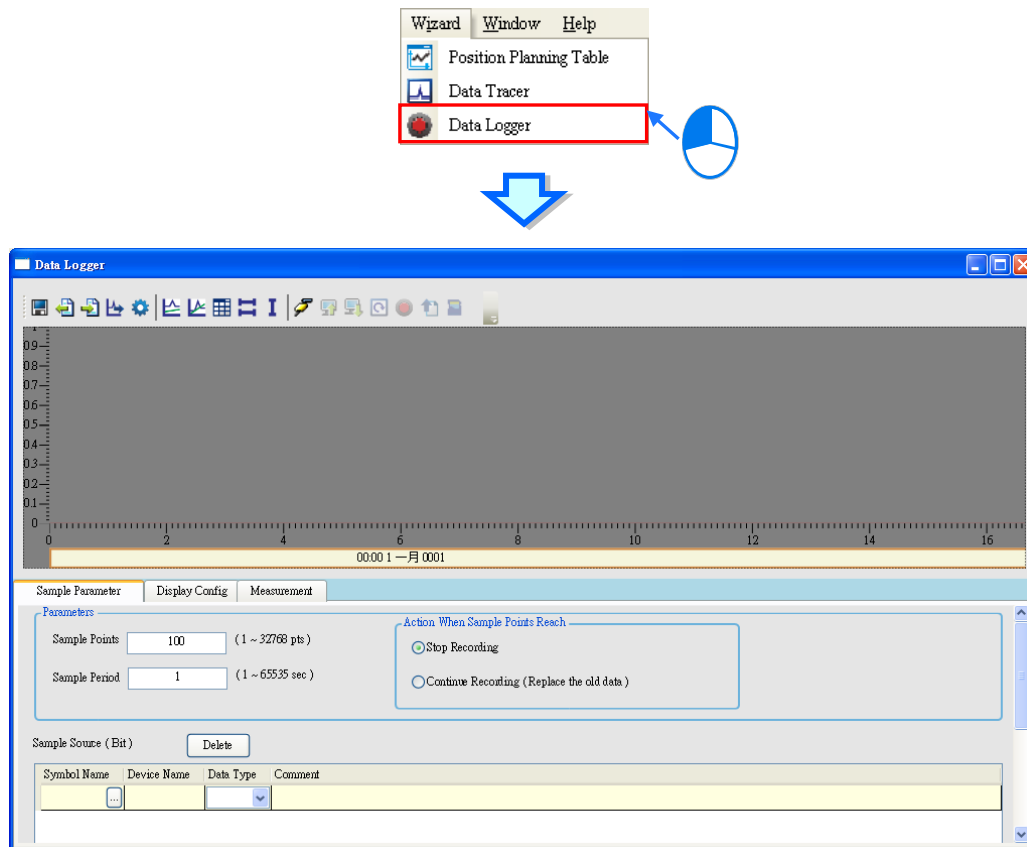

## 6. User-defined Data Type (UDT) / Data Type Unit (DUT)

- Sometimes basic data types are not sufficient for users to write their own programs for the PLC. In the IEC 61131-3 standard, a high-level language such as the user-defined data type is adopted to create a new data type as users desired, allowing users to define their own variables and improving the readability and the efficiency of developing a program.

(1) Structure: a structure is the collection of data, consisting of same amount various data types. Structured or array elements can be elements for other structures. A structure is used for grouping data and can be seen as a data unit to transfer parameters.

(2) Enumeration: users can enumerate the elements in a collection of objects, providing an efficient way to define a set of named integral constants that may be assigned to a variable and values that the enumeration represents.

## Version: 3.02

Date of Publication: July 25, 2016

1. ISPSOft V3.02 now supports VFD-MS300, VFD-MH300, AS332T, AS332P and AS324MT models.
2. ISPSOft V3.02 now supports AH08EMC-5A, AH10EMC-5A, AH20EMC-5A models. (Henceforth, the three product series, AH08EMC-5A, AH10EMC-5A, AH20EMC-5A will be referred to as AHxxEMC series.)
3. HWCONFIG for newly added models in AS series
  - Designed with no backplane, the CPU module in AS series are equipped with function card slots and can support right-side extensions. Module setups can be done in HWCONFIG; as for the extension module setups, users need to go to the PLC parameter setting window. The setups will be updated in HWCONFIG and the information list simultaneously.

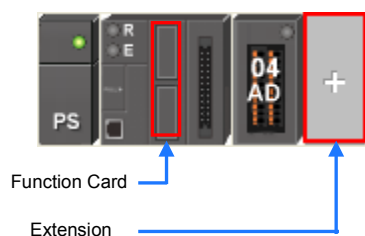

4. HWCONFIG for newly added models in AHxxEMC series  
Be sure to refer to the relative manuals before any setup. In order to prevent any personal injury or property damage, make sure all the setups are done logically.

Double click HWCONFIG to go to HWCONFIG page and double click the CPU icon to go to the setting page.

There are various setting options on the setting page. Select the option tab on the top, users will see detailed setting items are listed and categorized into 6 groups, Parameter name, Value, Unit, Default, Minimum and Maximum on the right side of the page for users to configure. Select other tabs on the top for different data exchanges.

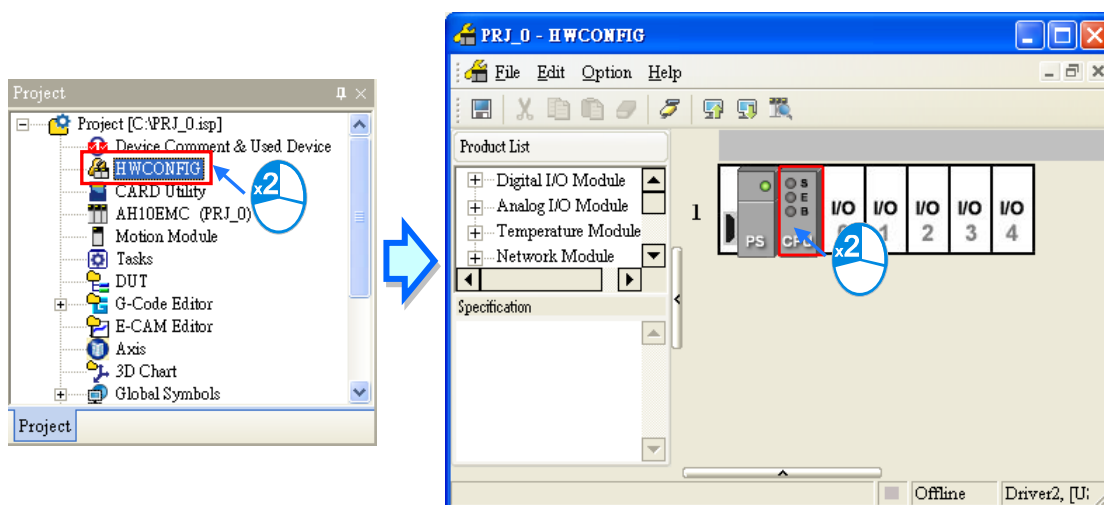

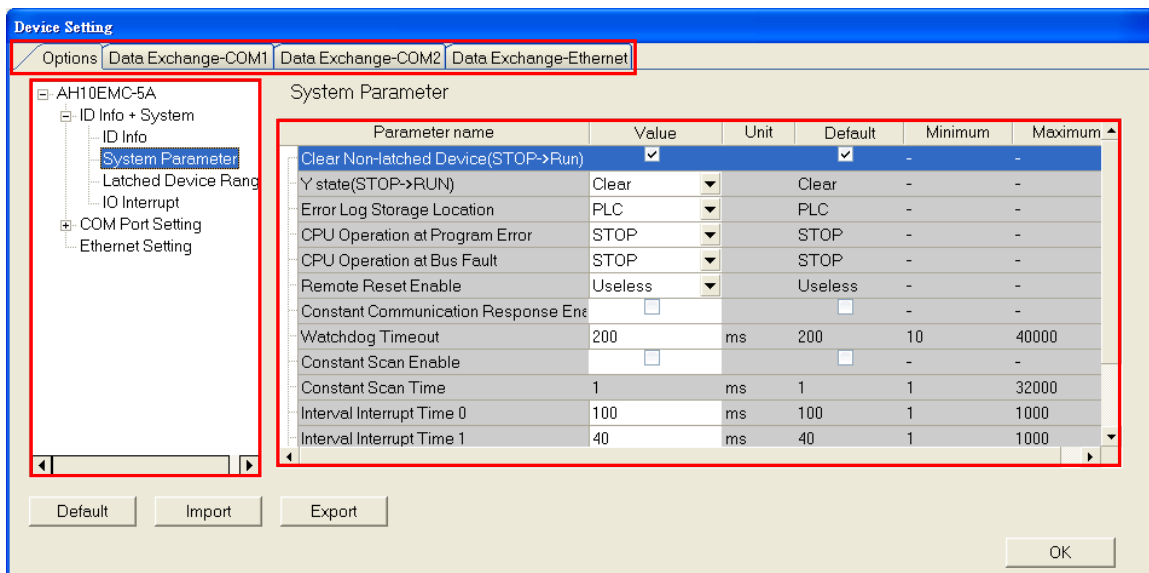

## 5. Newly added Main Table and Axis Table for AHxxEMC Series

Axis provides a connection between the motion control in the program and the physical output device. Axis stores various motion control information such as position, velocity and so on.

Global symbols are classified for easier management; there are different sub-items including **Main Table**, **Axis Table** and **Other Network Symbol Table** under global symbols. **Main Table**, same as the global symbols of other models, is used for editing the global symbols. **Axis Table** lists all axis variable names which have already been created. **Other Network Symbol Table** contains the symbols used in other network configuration software such as ECAT Builder. For details on other network configuration software, refer to operation manuals of the software.

After the axis is created, the identifier of the axis variable name will appear automatically in **Axis Table** under **Global Symbols**. Double-click **Axis Table** to open the **Axis Table** window.

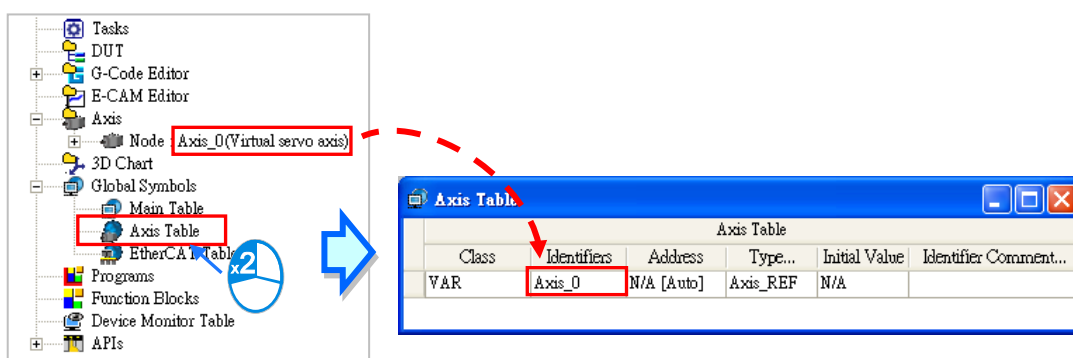

## 6. Newly added Axis Parameter, Monitor and Test Run for AHxxEMC Series

AxisParaForm, the parameter setting window of the axis will be opened automatically once the axis node item is created. Users can double-click Axis Parameter under the axis node item to open the AxisParaForm window once more after the window is closed. All settings on motion control of the axis are listed in the window as below. For details of axis parameters, refer to the

user manuals of modules. The set values can be downloaded to the PLC with the project together after the setting is done. Refer to their relative manuals on how to upload and download the settings.

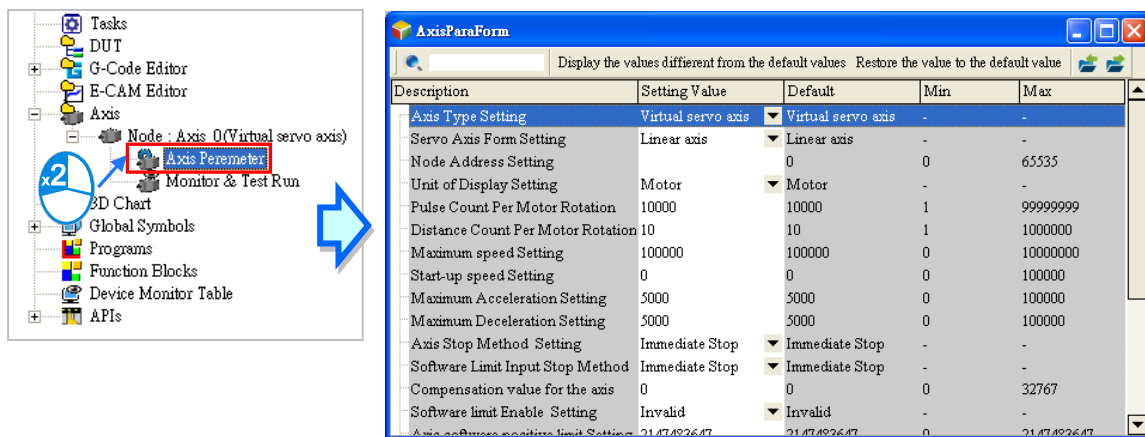

## 7. Newly added G-Code Editor for AHxxEMC Series

There are 2 options under the G-Code Editor, select G-Code to save the codes in the PLC and G-Code (External SD Card) to save the codes to the external SD Card on the PLC. Select one of the options and right-click the selected option and then click New to open the New G-Code Program setting window. Type a name and an item ID for this G-Code. Users can also set up a password to protect the G-Code data. When a password is set, the system will ask for the password upon next editing. Up to 32 sets of G-Code can be created (max. 64KB for each set) in the PLC and up to 128 sets of G-Code can be created (max. 2MB for each set) in the external SD card.

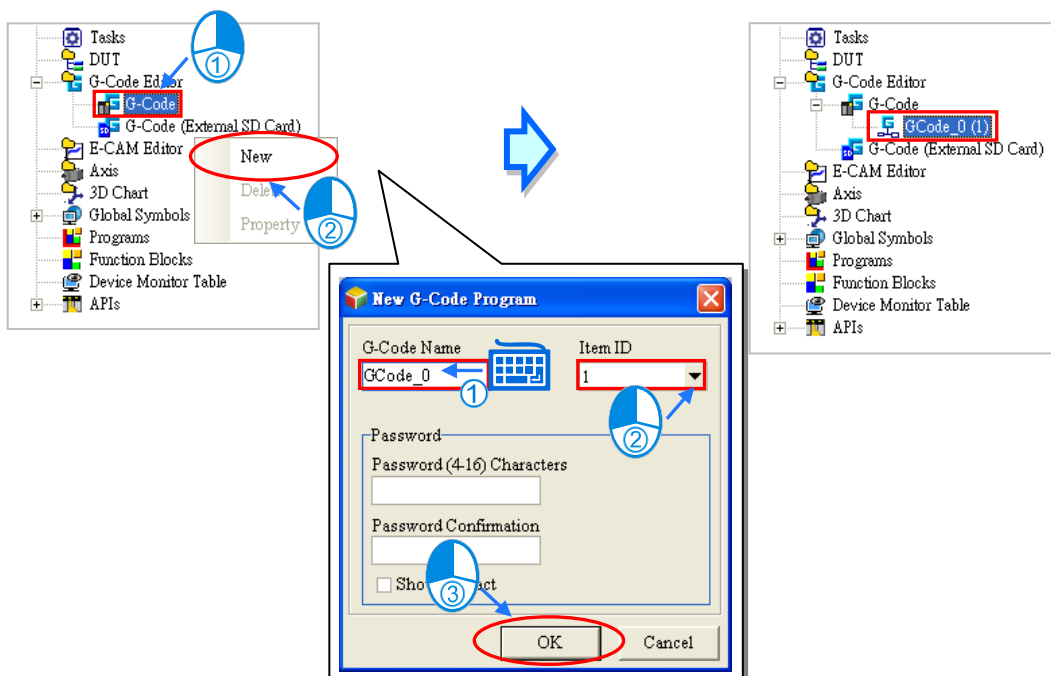

While writing a G-Code in the programming area, the current drawing G-Code will be shown in red in the toolpath view area. Users can right-click, hold and drag the mouse to rotate the toolpath in the toolpath view area.

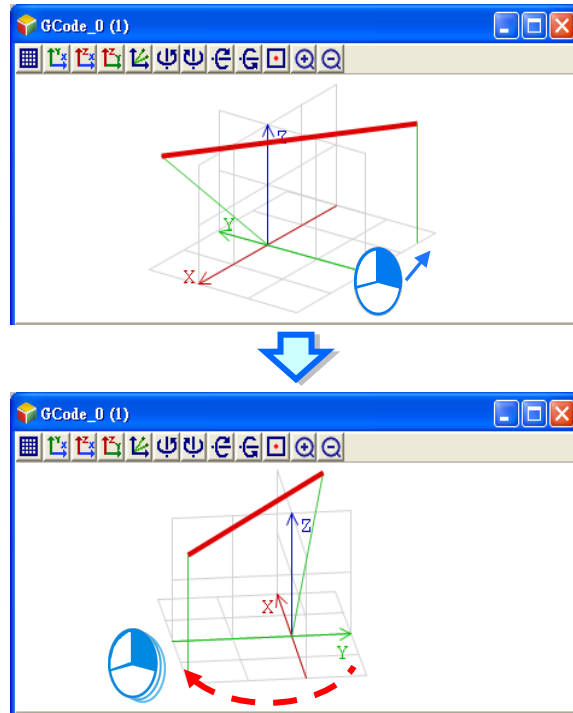

## 8. Newly added E-CAM Editor for AHxxEMC Series

An E-CAM is to use a cam chart to define the relation between a follower and a cam to simulate the movements of a cam controlled by a PLC, making a slave axis to move by the master axis according to their defined relation. The benefit of using an E-CAM is that users can modify the electronic cam data in an electronic cam in software. Users do not need to modify the mechanical design and no concern on the machinery wear and tear.

Right-click the E-CAM Editor in the project management area and then click New to see a New E-CAM Chart setting window. Type a name and an item ID for this chart. Users can also set up a password to protect the E-CAM data. When a password is set, the system will ask for the password upon next editing. Up to 32 sets of E-CAM can be created.

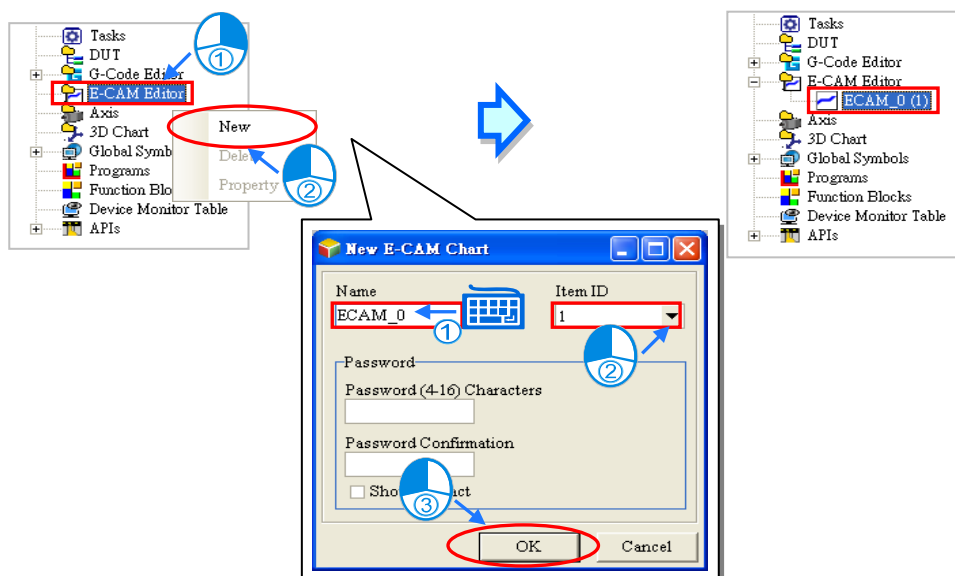

Users can click the Insert a point icon  and then click where they'd like to add the data point on the chart. The new data point will be added on the chart and the relative data will be shown in the Data setting area simultaneously. Up to 20 rows can be added.

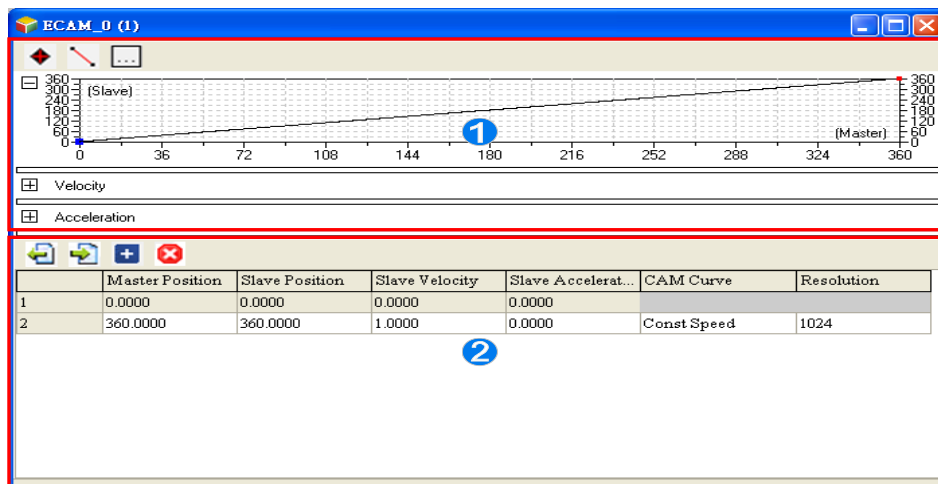

9. The online program monitoring function is enhanced: the updating speed is improved while performing multi-pages program monitoring.
10. ISPSOft V3.02 supports Continuous Function Chart (CFC) programming language for AS300 series. (For detailed illustrations on the CFC programming, please refer to the ISPSOft User Index in the Help section of IS

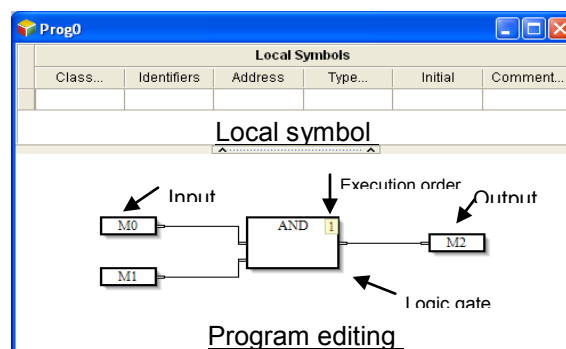
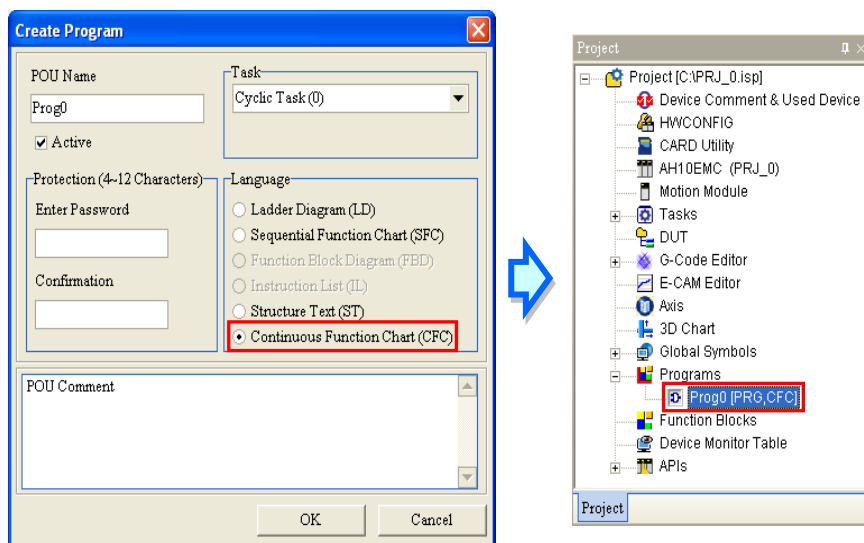

11. ISPSOft V3.02 supports EIP Tags for AS300 series.

- There are 2 kinds of EIP Tags, including the Produced Tag and Consumed Tag. Symbols in the EtherNet/IP Table can be used the same way as the global symbols can be used. For the creation and usage of a symbol, please refer to the ISPSOft User Index in the Help section of ISPSOft.
- Once the definitions of the Produced Tag and Consumed Tag are complete, the specified EIP tags will also be downloaded with PLC programs to the PLC. As for the data exchange through the EIP tags in the PLC, it can be done with the EIP Builder. Please refer to the EIP Builder manual for further instructions.

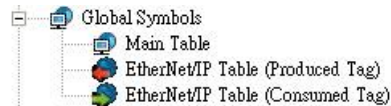

12. ISPSOft V3.02 adds a High Speed Counter tool for AS300 series.

- The high speed counter tool allows users to select the number of the corresponding high speed counter based on the type of the high speed counter, format of the value to be counted and input point number so that DCNT instruction can be set quickly.
- Double-click DCNT instruction in the ladder diagram to open the High Speed Counter Setting window as the image shown below. (For detailed illustrations on the High Speed Counter Tool, please refer to the ISPSOft User Index in the Help section of ISPSOft.)

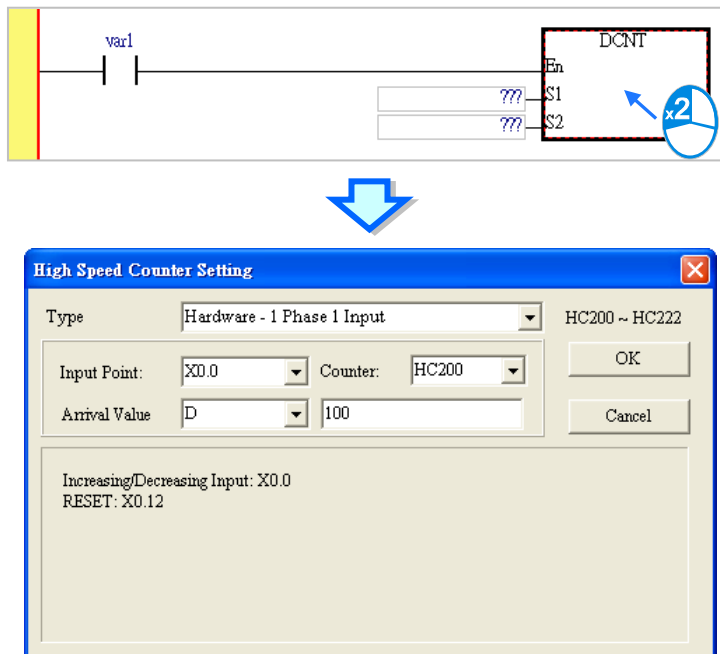

13. Four new instructions, including DSPD, PWD, MPG and DPPGB are added for AS300 series. For detailed descriptions, please refer to the attachment.

14. Position Planning Table for AS300 series

- ISPSOft V3.02 provides an easy table for users to set up the single-axis or 2-axis motion control. It is not required for users to know the complicated motion control rules to complete the setup. Create and download a position planning table and then along with the instructions, the PLC can output axis motions in the set number and order accordingly.

Click **Wizard (!) > Position Planning Table** on the tool bar to open the **Position Planning Table** window as the image shown below.

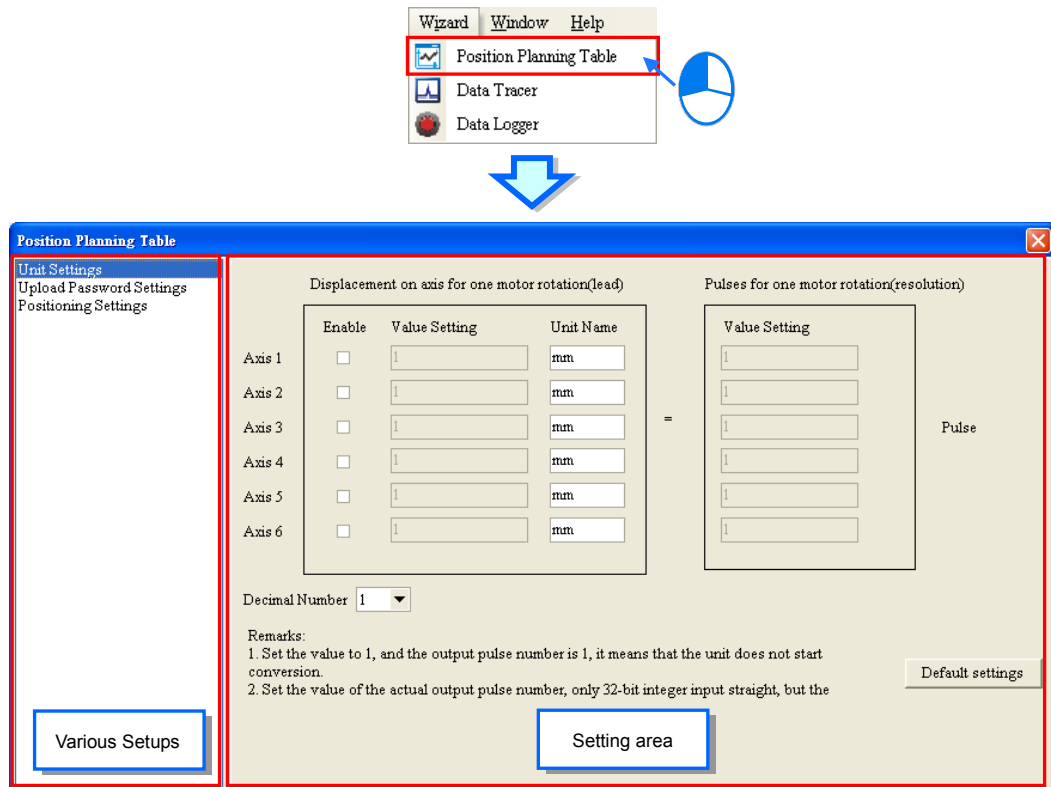

## 15. Data Tracer for AS300 series

- Data Tracer is used for the real-time collection of variable symbols or values or states in devices after some trigger condition is met so as to draw curve charts for analysis of value trends.

Before using this functionality, users need to complete the programming for the current project. Click **Wizard (!) > Data Tracer** on the tool bar to open the Data Tracer setup window as the image shown below.

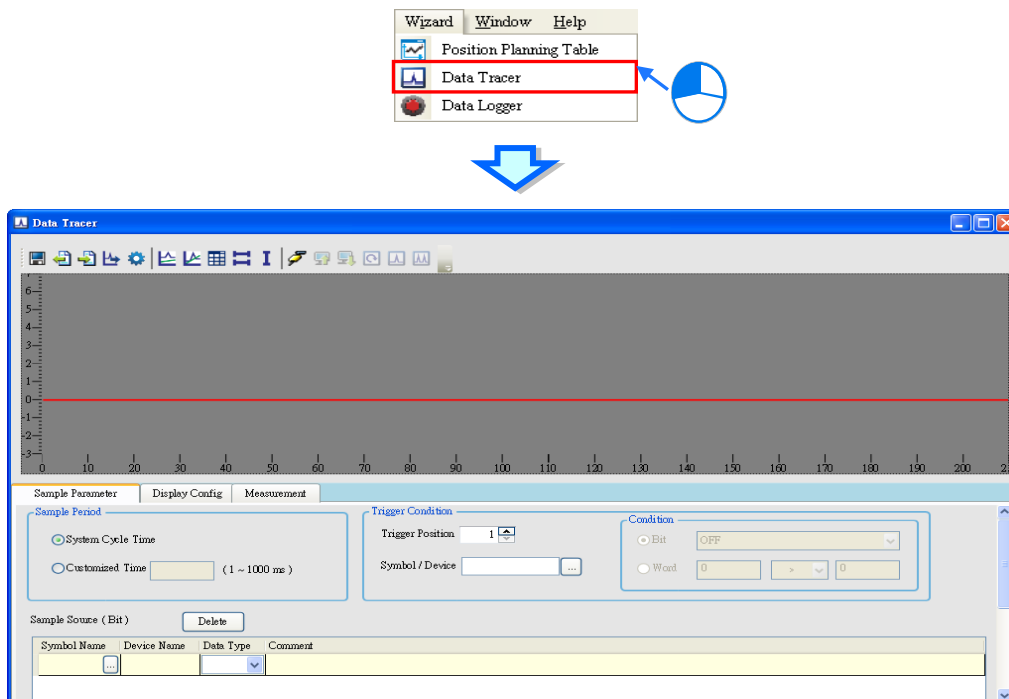

## 16. Data Logger for AS300 series

- Data Logger can be used to collect the long-term records of the variable symbols or values/states of a device to create a diagram of curve for users to analyze.

Before using this functionality, users need to complete the programming for the current project. Click Wizard (!) > Data Logger on the tool bar to open the Data Logger setup window as the image shown below.

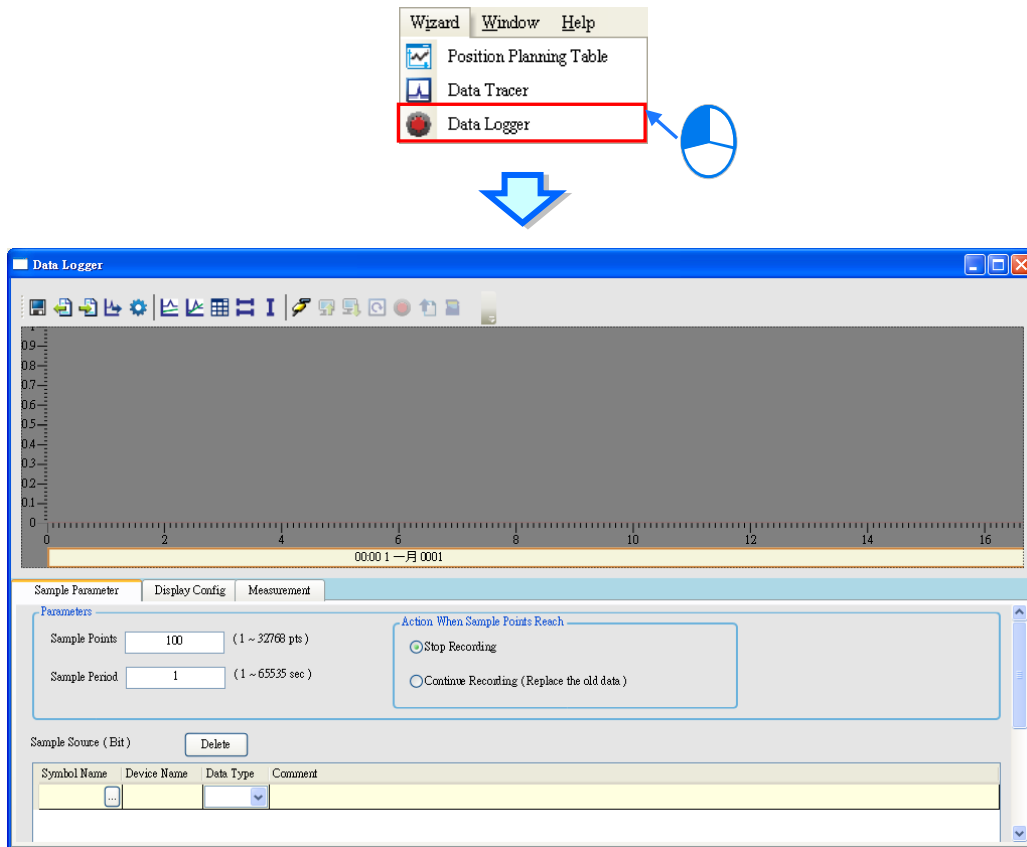

## 17. User-defined Data Type (UDT) / Data Type Unit (DUT)

- Sometimes basic data types are not sufficient for users to write their own programs for the PLC. In the IEC 61131-3 standard, a high-level language such as the user-defined data type is adopted to create a new data type as users desired, allowing users to define their own variables and improving the readability and the efficiency of developing a program.

- (1) Structure: a structure is the collection of data, consisting of same amount various data types. Structured or array elements can be elements for other structures. A structure is used for grouping data and can be seen as a data unit to transfer parameters.
- (2) Enumeration: users can enumerate the elements in a collection of objects, providing an efficient way to define a set of named integral constants that may be assigned to a variable and values that the enumeration represents.

Download the software at

<http://www.deltaww.com/services/DownloadCenter2.aspx?secID=8&pid=2&tid=0&CID=06&itemID=060301&typeID=1&downloadID=&title=-- Select Product Series --&dataType=8;&check=1&hl=en-US>